



TAMA
TAMA[®]
SUPERSTAR

TAMA[®]

DRUMS AND HARDWARE

Price List 2024

Forint (HU)



REGULAR SNARE DRUMS

MASTERCRAFT "THE BELL BRASS"

In 1980, the TAMA Mastercraft Bell Brass snare drum was born. At the time, the Bell Brass was designed to match the explosive sounds of a new decade in music and delivered the purest snare sound ever achieved. Widely used in heavy rock music of the 80s and 90s, TAMA's Bell Brass snare drum came to simply be known as "THE TERMINATOR". As aggressive of a sound it produced, its versatility was unmatched as it found its way into the hands of the world's top Jazz & Fusion drummers of the era.

Now, nearly half a century later, the TAMA Mastercraft "The Bell Brass" 50th Anniversary Reissue pays tribute to this legendary sound. Featuring a special alloy of copper and tin and molded into a 3mm thick shell, this super heavy bell brass shell produces extreme volume and outstanding tonal range.

Faithfully reproduced to original specifications as much as modern technology allows, the Mastercraft "The Bell Brass" 50th Anniversary Reissue brings the iconic & timeless sound to drummers once again.



BB-156

Shell: 3mm Cast Bell Brass

Size: 14"x6.5"

Lug: Original Superstar Lug (6371N)

Hoop: Die-Cast Hoop (10 hole)

Strainer/Butt: Roller Action (6302N/6303N/6338N)

Snare Wire: 20 strands Carbon Steel Long Snare Wires (6035N)

Inside Muffler: One Touch Tone Control (6552N)

Head: REMO® Ambassador Coated TAMA 50th Anniversary version

1.540.000,00



355mm diameter, 3mm Cast Bell Brass Shell



Die-Cast Hoop (10 hole)



20 strands Carbon Steel Long Snare Wires (6035N)



Original Superstar Badge



One Touch Tone Control



REMO® Ambassador Coated
TAMA 50th Anniversary version





LIMITED SNARE DRUMS

50TH LIMITED MASTERCRAFT ROSEWOOD

In the 1980s, TAMA's Mastercraft Rosewood Snare Drum was the first and only drum of its kind. As a hard and dense material, Rosewood is commonly used as guitar fretboards, and at the time was only found on drums as a single outer-ply veneer. Full Rosewood drums are extremely difficult to produce, but their pure sound and dark tone makes them extremely popular among drummers looking for a new sound. Not long after the original release of the Mastercraft Rosewood Snare Drum, the TAMA brand became synonymous with Rosewood. This 50th Anniversary Limited Edition model faithfully reproduces the sound of the past. Familiar to those who were there at the beginning, and an exciting new discovery to those who weren't.



RW-256

Shell: 7.5mm 15ply Indian Rosewood
Size: 14"x6.5"
Lug: Original Superstar Lug (6371N)
Hoop: Die-Cast Hoop (10 hole)
Strainer/Butt: Roller Action (6302N/6303N/6338N)
Snare Wire: 20 strands Carbon Steel Long Snare Wires (6035N)
Inside Muffler: One Touch Tone Control (6552N)
Head: REMO® Ambassador Coated TAMA 50th Anniversary version

385.000,00



RW-255

Shell: 7.5mm 15ply Indian Rosewood
Size: 14"x5"
Lug: Original Superstar Lug (6371N)
Hoop: Die-Cast Hoop (10 hole)
Strainer/Butt: Roller Action (6302N/6303N/6338N)
Snare Wire: 20 strands Carbon Steel Long Snare Wires (6035N)
Inside Muffler: One Touch Tone Control (6552N)
Head: REMO® Ambassador Coated TAMA 50th Anniversary version

377.000,00

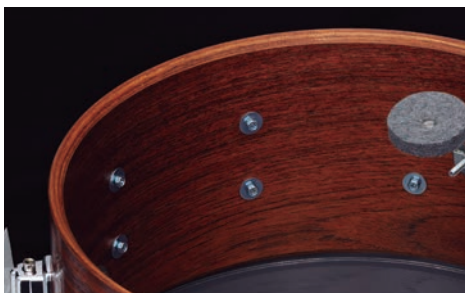

7.5mm, 15ply All Indian Rosewood Shell



Die-Cast Hoop (10 hole)

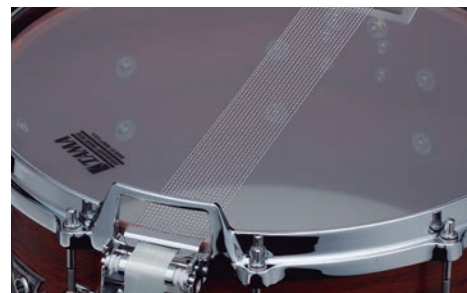

20 strands Carbon Steel Long Snare Wires (6035N)



One Touch Tone Control



Inside Muffler



REMO® Ambassador Coated
TAMA 50th Anniversary version



LIMITED SNARE DRUMS

50TH LIMITED MASTERCRAFT ARTWOOD

Released in 1980, fans of the Mastercraft Artwood snare drum have eagerly awaited its reissue. Known for its obviously stunning looks, this snare drum is adorned with a beautifully stained multi-section center wood inlay. The 9mm/6ply all-Birch shell delivers significant low-mid tone and clear projection. For a detailed & sensitive snare response, the drum features TAMA's unique Roller Action Strainer, an innovative full-contact snare wire design that utilizes a single on/off lever & dual guide rollers for easy & versatile adjustment.

This faithful reproduction of TAMA's original Mastercraft Artwood snare drum is an amazingly beautiful celebration of TAMA's 50th Anniversary.



AW-456

Shell: 9mm 6ply Birch with center wood inlay
Size: 14"x6.5"
Lug: Original Superstar Lug (6371N)
Hoop: Die-Cast Hoop (10 hole)
Strainer/Butt: Roller Action (6302N/6303N/6338N)
Snare Wire: 20 strands Carbon Steel Long Snare Wires (6035N)
Inside Muffler: One Touch Tone Control (6552N)
Head: REMO® Ambassador Coated TAMA 50th Anniversary version

346.000,00



AW-455

Shell: 9mm 6ply Birch with center wood inlay
Size: 14"x5"
Lug: Original Superstar Lug (6371N)
Hoop: Die-Cast Hoop (10 hole)
Strainer/Butt: Roller Action (6302N/6303N/6338N)
Snare Wire: 20 strands Carbon Steel Long Snare Wires (6035N)
Inside Muffler: One Touch Tone Control (6552N)
Head: REMO® Ambassador Coated TAMA 50th Anniversary version

338.000,00

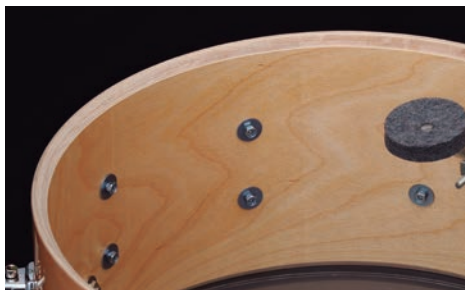

9mm, 6ply All Birch shell



Die-Cast Hoop (10 hole)



20 strands Carbon Steel Long Snare Wires (6035N)



One Touch Tone Control

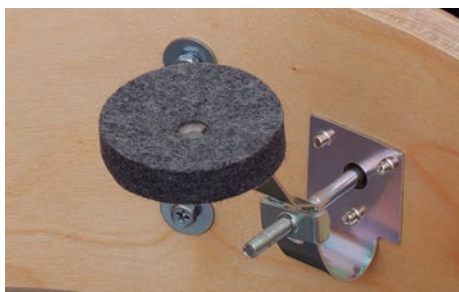

Inside Muffler



REMO® Ambassador Coated
TAMA 50th Anniversary version



LIMITED SNARE DRUMS

50TH LIMITED MASTERCRAFT STEEL

Popular amongst vintage drum lovers, the Mastercraft Steel Snare Drum features a classic chrome finish and center groove design for a distinct and understated look. This 50th Anniversary Reissue model features a 1.2mm steel shell and die-cast hoops producing a clean, bright attack with clear and crisp resonance. Complete with full-surface snare wires for enhanced articulation, the Mastercraft Steel 50th Anniversary Reissue Snare Drum perfectly delivers the sound of the 80s.



8056

Shell: 1.2mm Steel
Size: 14"x6.5"
Lug: Original Superstar Lug (6371N)
Hoop: Die-Cast Hoop (10 hole)
Strainer/Butt: Roller Action (6302N/6303N/6338N)
Snare Wire: 20 strands Carbon Steel Long Snare Wires (6035N)
Inside Muffler: One Touch Tone Control (6552N)
Head: REMO® Ambassador Coated TAMA 50th Anniversary version

308.000,00

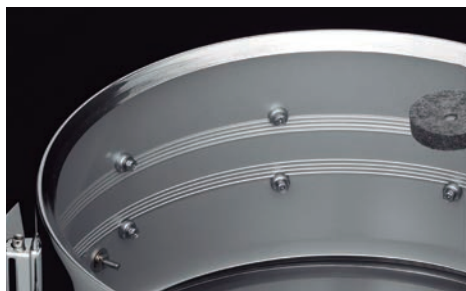

1.2mm Steel Shell



Die-Cast Hoop (10 hole)



20 strands Carbon Steel Long Snare Wires (6035N)





LIMITED 50TH LIMITED SUPERSTAR REISSUE

Released just 2 years after the birth of the TAMA brand, Superstar drums were dynamic and powerful, laying the groundwork for the future of TAMA's sound. Now, almost 50 years later, the original Superstar drums have been revived as a Limited Edition model to celebrate the 50th Anniversary of TAMA Drums. Superstar was the world's first drum kit to utilize an all-Birch shell, producing the perfect sound for the emerging genres of the time - a sound that captivated the top drummers in the world. The groundbreaking 6-ply/9mm shell design was crucial to Superstar's monumental success. Thicker than modern drums, these shells achieved powerful attack and deep low end. Honoring TAMA's 50th Anniversary, the original shells, period correct shell hardware, and matching interior finish deliver a faithful reproduction of the original Superstar. Available in 4 popular original colors: Aqua Marine, Cherry Wine, Super Mahogany, and Super Maple. After 50 years, we celebrate the origin of TAMA's sound with the Superstar Reissue.



COLOR Aqua Marine (AQM)

SU42RS basic kit

- Including
- 22"x14" Bass Drum
- 10"x8" & 12"x8" Tom Toms
- 16"x16" Floor Tom
- MTH800 Double Tom Holder

770.000,00



Shell: 6ply/9.0mm All Birch



Original Superstar Badge



REMO® Head

AVAILABLE FINISHES



Aqua Marine (AQM)



Super Maple (SPM)



Super Mahogany (SMH)



Cherry Wine (CHW)



LIMITED 50TH LIMITED STARCLASSIC MIRAGE

Since the 1970s, acrylic drums have been sought after for their unique sound and sleek look. Over the last two decades, TAMA has released limited edition acrylic drum kits of our own, starting with the Starclassic Mirage in 2007. To commemorate TAMA's beginnings, the Starclassic Mirage will return as a limited edition 50th Anniversary model. Characterized by strong attack and thunderous tone, Starclassic Mirage's seamless acrylic shells delivers unmatched sound and stunning looks. In addition to its controlled, punchy, and rich sound, acrylic remains unaffected by changing climates, making it perfect for use in any environment. The darker Black Nickel shell hardware perfectly complements the clear shells, ensuring that audiences and drummers alike will be instantly captivated by their stage presence.



COLOR Crystal Ice (CI)

MBA52RZBNS basic kit

- Including
- 22"x16" Bass Drum
- 10"x7" & 12"x8" Tom Toms
- 14"x12" Floor Tom
- 16"x14" Floor Tom
- MC69 Single Tom Attachment x 2

962.000,00

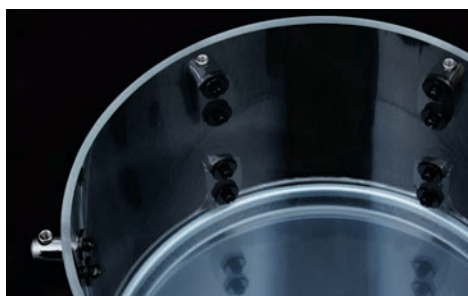

Shell:
BD: 6.5mm Seamless Acrylic
TT, FT: 5.5mm Seamless Acrylic



Black Nickel Shell Hardware



ADD-ON SNARE DRUM



MBAS65BN

- Shell: 5.5mm Seamless Acrylic
- Size: 14"x6.5"
- Lug: MSL-SCTBN
- Hoop: Die Cast Hoops (10 hole)
- Strainer/Butt: MLS30ABN/MLS30BBN
- Snare Wire: 20 strands Super Sensitive Hi-Carbon Snare Wires (MS20RL14C)
- Color: Crystal Ice (CI)

173.000,00



LIMITED 50TH LIMITED IRON COBRA MARBLE Coral Swirl

HP900PMCS / HP900PWMCS / HP900RMCS / HP900RWMCS

Since its release in 1993, the Iron Cobra has been the world's most highly rated pedal. At the core of the Iron Cobra series sits originality, and an unwavering commitment to constant innovation and evolution. With numerous limited edition models over the last two decades, this 50th Anniversary Limited Edition model serves as a special celebration of the Iron Cobra's long and storied history. Featuring two colorful designs, Coral Swirl and Psychedelic Rainbow, the Iron Cobra Marble Edition pedals are visually stunning, yet again setting the Iron Cobra apart from all others in its class.



HP900PMCS
Power Glide Single Pedal

154.000,00



HP900PWMCS
Power Glide Twin Pedal

327.000,00



HP900RMCS
Rolling Glide Single Pedal

154.000,00



HP900RWMCS
Rolling Glide Twin Pedal

327.000,00

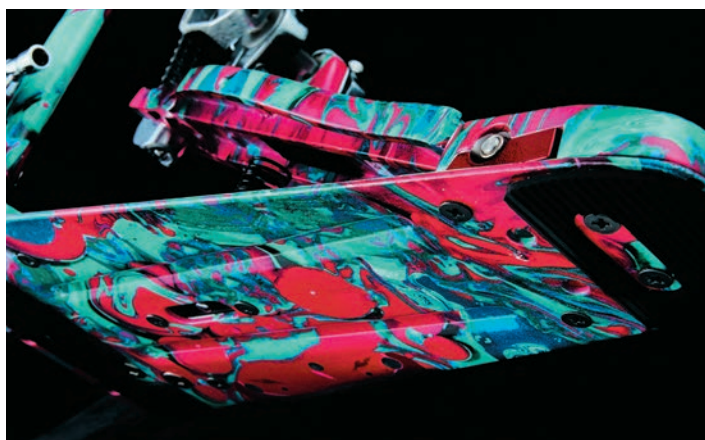



LIMITED 50TH LIMITED IRON COBRA MARBLE Psychedelic Rainbow

HP900PMPR / HP900PWMPR / HP900RMPR / HP900RWMPR

Since its release in 1993, the Iron Cobra has been the world's most highly rated pedal. At the core of the Iron Cobra series sits originality, and an unwavering commitment to constant innovation and evolution. With numerous limited edition models over the last two decades, this 50th Anniversary Limited Edition model serves as a special celebration of the Iron Cobra's long and storied history. Featuring two colorful designs, Coral Swirl and Psychedelic Rainbow, the Iron Cobra Marble Edition pedals are visually stunning, yet again setting the Iron Cobra apart from all others in its class.



HP900PMPR
Power Glide Single Pedal

154.000,00



HP900PWMPR
Power Glide Twin Pedal

327.000,00



HP900RMPR
Rolling Glide Single Pedal

154.000,00



HP900RWMPR
Rolling Glide Twin Pedal

327.000,00





LIMITED ACCESSORIES

50TH LIMITED QUICK-SET CYMBAL MATE - QC8

TAMA's best-selling Quick-Set Cymbal Mate is available in three vibrant 50th Anniversary Limited Edition colors - Gray, Orange, and Purple.



QC8B4GY

6.810,00



QC8B4OR

6.810,00



QC8B4PU

6.810,00

*Only 4pcs/set is available

50TH LIMITED DRUM RUG

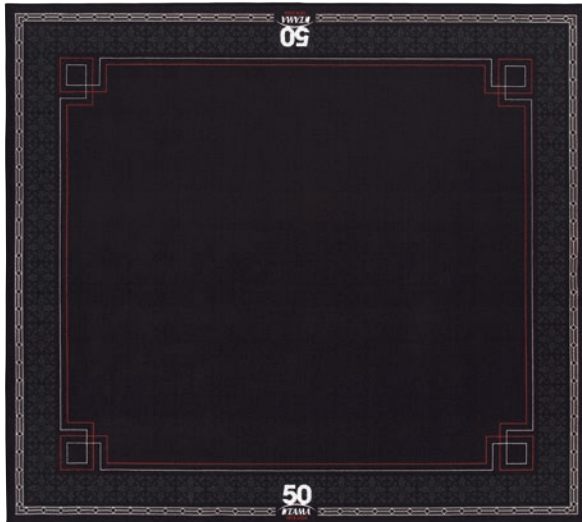

TDR-50TH

A drum rug is an essential item for every drummer. This limited edition rug celebrates TAMA's 50th Anniversary and features an original and classy 50th Anniversary design.

63.000,00

Size: 2,000mm x 1,800mm (78 3/4" x 70 7/8")



50TH LIMITED DRUMSTICKS

Available as a 50th Anniversary Limited Edition model, TAMA releases a drumstick made from 100% Japanese Oak. With over 60 years of history, TAMA drumsticks date back to the brand's earliest years, and have remained popular amongst drummers around the world for their high-end and consistent quality.



5A-50TH

Material: Japanese Oak
Diameter: 14mm
Length: 406mm
Tip Style: 5A

4.580,00



5B-50TH

Material: Japanese Oak
Diameter: 15mm
Length: 406mm
Tip Style: 5B

4.580,00



7A-50TH

Material: Japanese Oak
Diameter: 13mm
Length: 390mm
Tip Style: 7A

4.580,00





Starclassic **Mirage**

TAMA STAR BUBINGA

Lacquer Finishes

STAR is the flagship line for TAMA drums. It takes the knowledge and research we cultivated for the Starclassic series to the next level, by reexamining every detail to enhance shell resonance. STAR Bubinga features a thin 5mm shell. Every shell comes equipped with 9mm thick Sound Focus Rings (SFR) for structural support. This shell configuration provides clear projection and resonance to highlight the distinct sound of Bubinga.



COLOR Pewter Blue Australian Acacia **PBA**

including:
22"x16" bass drum
8"x6" tom tom
10"x7" tom tom
12"x8" tom tom
14"x12" floor tom
16"x14" floor tom
14"x6.5" snare drum



COLOR Solid Candy Red **SDR**

including:
20"x16" bass drum
8"x7" tom tom
10"x7" tom tom
12"x7" tom tom
13"x7.5" tom tom
14"x12" floor tom
16"x14" floor tom
14"x6.5" snare drum

INDIVIDUAL MODEL NUMBERS

Diameter	Depth	Model No.	
Bass Drums			
16"	12"	TBB1612S	893.000,00
18"	14"	TBB1814S	916.000,00
18"	15"	TBB1815S	916.000,00
18"	16"	TBB1816S	916.000,00
20"	14"	TBB2014S	951.000,00
20"	16"	TBB2016S	951.000,00
20"	17"	TBB2017S	951.000,00
20"	18"	TBB2018S	951.000,00
22"	14"	TBB2214S	1.001.000,00
22"	16"	TBB2216S	1.001.000,00
22"	17"	TBB2217S	1.001.000,00
22"	18"	TBB2218S	1.001.000,00
24"	14"	TBB2414S	1.055.000,00
24"	16"	TBB2416S	1.055.000,00
24"	17"	TBB2417S	1.055.000,00
24"	18"	TBB2418S	1.055.000,00
26"	14"	TBB2614S	1.143.000,00
26"	16"	TBB2616S	1.143.000,00
Floor Toms			
13"	12"	TBF1312S	504.000,00
14"	12"	TBF1412S	516.000,00
14"	13"	TBF1413S	516.000,00
14"	14"	TBF1414S	516.000,00
15"	13"	TBF1513S	546.000,00
15"	14"	TBF1514S	546.000,00
15"	15"	TBF1515S	546.000,00
16"	14"	TBF1614S	581.000,00
16"	15"	TBF1615S	581.000,00
16"	16"	TBF1616S	581.000,00
18"	14"	TBF1814S	612.000,00
18"	15"	TBF1815S	612.000,00
18"	16"	TBF1816S	612.000,00

Diameter	Depth	Model No.	
Tom Toms			
8"	6"	TBT0806S	323.000,00
8"	7"	TBT0807S	323.000,00
8"	8"	TBT0808S	323.000,00
10"	6.5"	TBT1065S	354.000,00
10"	7"	TBT1007S	354.000,00
10"	8"	TBT1008S	354.000,00
10"	9"	TBT1009S	354.000,00
10"	10"	TBT1010S	354.000,00
12"	7"	TBT1207S	400.000,00
12"	8"	TBT1208S	400.000,00
12"	9"	TBT1209S	400.000,00
12"	10"	TBT1210S	400.000,00
12"	11"	TBT1211S	400.000,00
13"	7.5"	TBT1375S	442.000,00
13"	9"	TBT1309S	442.000,00
13"	10"	TBT1310S	442.000,00
13"	11"	TBT1311S	442.000,00
13"	12"	TBT1312S	442.000,00
14"	8"	TBT1408S	489.000,00
14"	10"	TBT1410S	489.000,00
14"	11"	TBT1411S	489.000,00
14"	12"	TBT1412S	489.000,00
14"	13"	TBT1413S	489.000,00
Snare Drums			
13"	6"	TBS136S	415.000,00
14"	5.5"	TBS1455S	415.000,00
14"	6.5"	TBS1465S	415.000,00
14"	8"	TBS148S	415.000,00

*Please ask price for "outside & inside inlay" option.

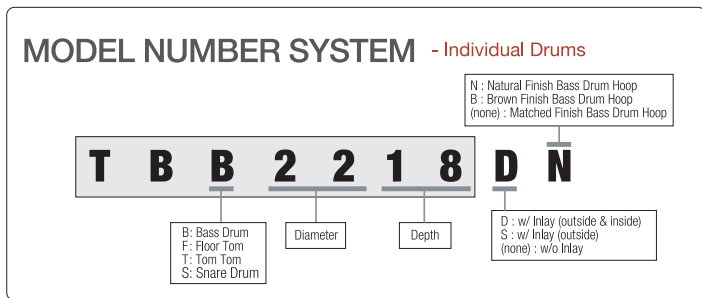

SPECIFICATIONS

Shells

5mm, 5ply Bubinga + 1 inner ply Cordia, or 5ply Bubinga + 1 outer ply Australian Acacia + 1 inner Ply Cordia for SAC/PBA, or 5ply Bubinga + 1 outer ply Indian Laurel + 1 inner ply Cordia for LNTI, or 4ply Bubinga + 1 outer & 1 inner ply Cordia for CDKG/CDKR, w/ 9mm Sound Focus Rings

STAR Bearing Edges

Super Resonant Mounting System

Quick-Lock Tom Brackets

Minimum Shell Contact

STAR Floor Tom Legs

Hold Tight™ Washers

Remo® Drum Heads

FINISHES (Lacquer)



Dark Green Cordia
CDKG



Dark Red Cordia
CDKR



Natural Indian Laurel
LNTI



Pewter Blue Australian Acacia
PBA



Sunset Australian Acacia Burst
SAC



Satin Blue Metallic
SBM



Antique White
ATW



Smoky Black
SKB



Atomic Orange
AMO



Grand Aqua Blue
GAQ



Solid Candy Red
SDR



Piano Black
PBK



Sunny Yellow Lacquer
SYL

TAMA STAR MAPLE

Lacquer Finishes

STAR is the flagship line for TAMA drums. It takes the knowledge and research we cultivated for the Starclassic series to the next level, by reexamining every detail to enhance shell resonance. STAR Maple shell's "Solid Core Ply" is a totally new design for this series. This unique shell provides the warm, open tone of Maple, combined with the rich, hearty sound of a solid ply shell.



COLOR Emerald Sea Curly Maple Burst **RECB**

including:
22"x16" bass drum
8"x6" tom tom
10"x7" tom tom
12"x8" tom tom
14"x14" floor tom
16"x16" floor tom
14"x6.5" snare drum



COLOR Gloss Natural Curly Maple **RGCM**

including:
22"x16" bass drum
8"x6" tom tom
10"x7" tom tom
12"x8" tom tom
14"x14" floor tom
16"x16" floor tom
14"x6.5" snare drum

INDIVIDUAL MODEL NUMBERS

Diameter	Depth	Model No.	
Bass Drums			
16"	12"	TMB1612S	893.000,00
18"	14"	TMB1814S	916.000,00
18"	15"	TMB1815S	916.000,00
18"	16"	TMB1816S	916.000,00
20"	14"	TMB2014S	951.000,00
20"	16"	TMB2016S	951.000,00
20"	17"	TMB2017S	951.000,00
20"	18"	TMB2018S	951.000,00
22"	14"	TMB2214S	1.001.000,00
22"	16"	TMB2216S	1.001.000,00
22"	17"	TMB2217S	1.001.000,00
22"	18"	TMB2218S	1.001.000,00
24"	14"	TMB2414S	1.055.000,00
24"	16"	TMB2416S	1.055.000,00
24"	17"	TMB2417S	1.055.000,00
24"	18"	TMB2418S	1.055.000,00
26"	14"	TMB2614S	1.143.000,00
26"	16"	TMB2616S	1.143.000,00
Floor Toms			
13"	12"	TMF1312S	504.000,00
14"	12"	TMF1412S	516.000,00
14"	13"	TMF1413S	516.000,00
14"	14"	TMF1414S	516.000,00
15"	13"	TMF1513S	546.000,00
15"	14"	TMF1514S	546.000,00
15"	15"	TMF1515S	546.000,00
16"	14"	TMF1614S	581.000,00
16"	15"	TMF1615S	581.000,00
16"	16"	TMF1616S	581.000,00
18"	14"	TMF1814S	612.000,00
18"	15"	TMF1815S	612.000,00
18"	16"	TMF1816S	612.000,00

Diameter	Depth	Model No.	
Tom Toms			
8"	6"	TMT0806S	323.000,00
8"	7"	TMT0807S	323.000,00
8"	8"	TMT0808S	323.000,00
10"	6.5"	TMT1065S	354.000,00
10"	7"	TMT1007S	354.000,00
10"	8"	TMT1008S	354.000,00
10"	9"	TMT1009S	354.000,00
10"	10"	TMT1010S	354.000,00
12"	7"	TMT1207S	400.000,00
12"	8"	TMT1208S	400.000,00
12"	9"	TMT1209S	400.000,00
12"	10"	TMT1210S	400.000,00
12"	11"	TMT1211S	400.000,00
13"	7.5"	TMT1375S	442.000,00
13"	9"	TMT1309S	442.000,00
13"	10"	TMT1310S	442.000,00
13"	11"	TMT1311S	442.000,00
13"	12"	TMT1312S	442.000,00
14"	8"	TMT1408S	489.000,00
14"	10"	TMT1410S	489.000,00
14"	11"	TMT1411S	489.000,00
14"	12"	TMT1412S	489.000,00
14"	13"	TMT1413S	489.000,00
Snare Drums			
13"	6"	TMS136S	415.000,00
14"	5.5"	TMS1455S	415.000,00
14"	6.5"	TMS1465S	415.000,00
14"	8"	TMS148S	415.000,00

*Please ask price for "outside & inside inlay" option.

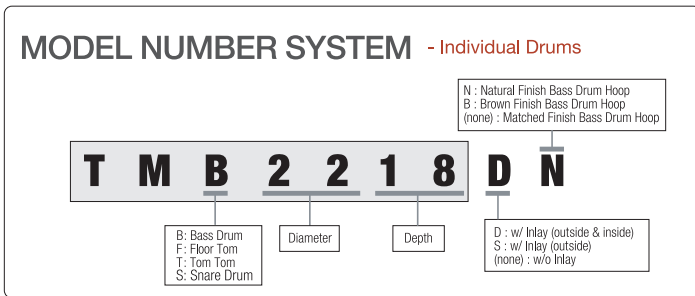

SPECIFICATIONS

Shells

5mm, 5ply Maple or 5ply Maple +1 outer ply Curly Maple for RGCM/RECB/ROLC/RRCM
 w/ 5mm Sound Focus Rings

- STAR Bearing Edges
- Super Resonant Mounting System
- Quick-Lock Tom Brackets
- Minimum Shell Contact
- STAR Floor Tom Legs
- Hold Tight™ Washers
- Remo® Drum Heads

FINISHES (Lacquer)



Gloss Natural Curly Maple
RGCM



Emerald Sea Curly Maple Burst
RECB



Ocean Blue Curly Maple
ROLC



Raspberry Curly Maple
RRCM



Satin Blue Metallic
SBM



Satin Antique Brown
SAB



Antique White
ATW



Smoky Black
SKB



Atomic Orange
AMO



Grand Aqua Blue
GAQ



Solid Candy Red
SDR



Piano Black
PBK



Sunny Yellow Lacquer
SYL

TAMA STAR WALNUT

Lacquer Finishes

STAR is the flagship line for TAMA drums. It takes the knowledge and research we cultivated for the Starclassic series to the next level, by reexamining every detail to enhance shell resonance. Walnut has long been favored by furniture makers for both its beauty and durability. As a drum shell material, Walnut's naturally EQ'ed tone has been praised by the drum community for both the stage and the studio. The STAR Walnut shells project booming low end with enough cut to be heard through any mix.



COLOR Antique White Japanese Chestnut **AWC**

TW42RZS basic kit

including:
22"x16" bass drum
10"x7" tom tom
12"x8" tom tom
16"x16" floor tom

[add-on]
14"x6.5" snare drum

KIT CONFIGURATIONS LIST

[22" BD 4pc Shell Kit]

TW42RZS

1.578.000,00

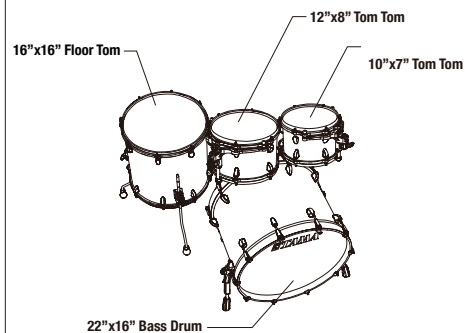

INDIVIDUAL MODEL NUMBERS

Diameter	Depth	Model No.	
Bass Drums			
16"	12"	TWB1612	623.000,00
18"	14"	TWB1814	643.000,00
18"	15"	TWB1815	643.000,00
18"	16"	TWB1816	643.000,00
20"	14"	TWB2014	673.000,00
20"	16"	TWB2016	673.000,00
20"	17"	TWB2017	673.000,00
20"	18"	TWB2018	673.000,00
22"	14"	TWB2214	708.000,00
22"	16"	TWB2216	708.000,00
22"	17"	TWB2217	708.000,00
22"	18"	TWB2218	708.000,00
24"	14"	TWB2414	750.000,00
24"	16"	TWB2416	750.000,00
24"	17"	TWB2417	750.000,00
24"	18"	TWB2418	750.000,00
26"	14"	TWB2614	816.000,00
26"	16"	TWB2616	816.000,00
Floor Toms			
13"	12"	TWF1312	354.000,00
14"	12"	TWF1412	362.000,00
14"	13"	TWF1413	362.000,00
14"	14"	TWF1414	362.000,00
15"	13"	TWF1513	388.000,00
15"	14"	TWF1514	388.000,00
15"	15"	TWF1515	388.000,00
16"	14"	TWF1614	408.000,00
16"	15"	TWF1615	408.000,00
16"	16"	TWF1616	408.000,00
18"	14"	TWF1814	439.000,00
18"	15"	TWF1815	439.000,00
18"	16"	TWF1816	439.000,00

Diameter	Depth	Model No.	
Tom Toms			
8"	6"	TWT0806	227.000,00
8"	7"	TWT0807	227.000,00
8"	8"	TWT0808	227.000,00
10"	6.5"	TWT1065	250.000,00
10"	7"	TWT1007	250.000,00
10"	8"	TWT1008	250.000,00
10"	9"	TWT1009	250.000,00
10"	10"	TWT1010	250.000,00
12"	7"	TWT1207	281.000,00
12"	8"	TWT1208	281.000,00
12"	9"	TWT1209	281.000,00
12"	10"	TWT1210	281.000,00
12"	11"	TWT1211	281.000,00
13"	7.5"	TWT1375	308.000,00
13"	9"	TWT1309	308.000,00
13"	10"	TWT1310	308.000,00
13"	11"	TWT1311	308.000,00
13"	12"	TWT1312	308.000,00
14"	8"	TWT1408	342.000,00
14"	10"	TWT1410	342.000,00
14"	11"	TWT1411	342.000,00
14"	12"	TWT1412	342.000,00
14"	13"	TWT1413	342.000,00
Snare Drums			
13"	6"	TWS136	292.000,00
14"	5.5"	TWS1455	292.000,00
14"	6.5"	TWS1465	292.000,00
14"	8"	TWS148	292.000,00

MODEL NUMBER SYSTEM - Individual Drums

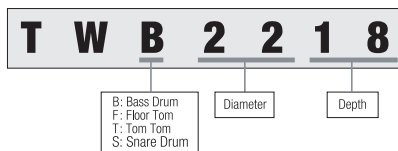

SPECIFICATIONS

Shells

All Walnut Shell TT/FT/SD: 6mm 6ply, BD: 7mm 7ply (except AUB, AGJB, ASBJ, ASCS, LIC, AWC, RSC)
 *AUB, AGJB, ASBJ, ASCS

TT/FT/SD: 6mm, 4ply Walnut + 2 outer ply Japanese Sen
 BD: 7mm, 5ply Walnut + 2 outer ply Japanese Sen

*LIC, AWC, RSC
 TT/FT/SD: 6mm, 5ply Walnut + 1 outer ply Japanese Chestnut
 BD: 7mm, 6ply Walnut + 1 outer ply Japanese Chestnut

STAR Bearing Edges

Super Resonant Mounting System

Quick-Lock Tom Brackets

Minimum Shell Contact

STAR Floor Tom Legs

Remo® Drum Heads

FINISHES (Lacquer)



Light Indigo Japanese Chestnut
LIC



Roasted Japanese Chestnut
RSC



Antique White Japanese Chestnut
AWC



Indigo Japanese Sen Burst
AJJB



Garnet Japanese Sen Burst
AGJB



Satin Black Japanese Sen Burst
ASBJ

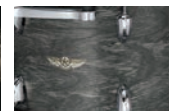

Satin Charcoal Japanese Sen
ASCS



Red Burgundy Walnut
RBW



Dark Mocha Walnut
DMW



Smoky Blue Mist
SBU



Antique White
ATW



Smoky Black
SKB

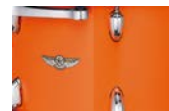

Atomic Orange
AMO



Grand Aqua Blue
GAQ



Solid Candy Red
SDR



Piano Black
PBW



Sunny Yellow Lacquer
SYL

STARCLASSIC MAPLE

Exotic Finishes

In the '80s TAMA's Superstars and Imperialstars reigned supreme - the perfect drums for the times. But TAMA's builders and designers wanted something that transcended trends, something timeless - drums that understood a player's passion and allowed the expression of every genre, style, mood, and technique. They created Starclassic Maple drums...and ignited the thin-shell revolution. And now the Exotic Finish line offers beautiful, one-of-a-kind exotic wood exteriors for that extra luxurious touch.

Numerous options are available to meet the varied and critical needs of professional drummers including a selection of about 30 different shell sizes. Starclassic Maple also features three shell hardware finishes to choose from: Black Nickel, Chrome and Smoked Black Nickel. Starclassic Maple is simply an unprecedented combination of sight and sound.



COLOR Tobacco Sunburst Movingui VTBV
w/ smoked black nickel hardware

ME42TZUS basic kit

including:

22"x16" bass drum
10"x7" tom tom
12"x8" tom tom
16"x16" floor tom

[add-on]

14"x6.5" snare drum

KIT CONFIGURATIONS LIST

[22" BD 3pc Shell Kit]

ME32CZS	w/ Chrome Hardware	1.155.000,00
ME32CZBS	w/ Black Nickel Hardware	1.155.000,00
ME32CZUS	w/ Smoked Black Nickel Hardware	1.155.000,00

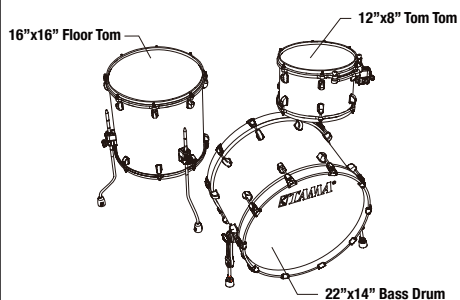

[22" BD 4pc Shell Kit]

ME42TZS	w/ Chrome Hardware	1.347.000,00
ME42TZBS	w/ Black Nickel Hardware	1.347.000,00
ME42TZUS	w/ Smoked Black Nickel Hardware	1.347.000,00

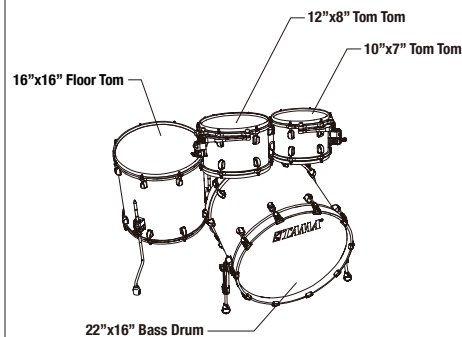

INDIVIDUAL MODEL NUMBERS

Diameter	Depth	Model No.			
		Black Nickel	Chrome	Smoked Black Nickel	
Bass Drums *To order Bass Drum w/ Tom Holder Base, Please substitute "Z" with "M". Ex MEB2218Z → MEB2218M					
16"	12"	MEB1612ZB	MEB1612Z	MEB1612ZU	535.000,00
18"	14"	MEB1814ZB	MEB1814Z	MEB1814ZU	562.000,00
20"	14"	MEB2014ZB	MEB2014Z	MEB2014ZU	579.000,00
20"	16"	MEB2016ZB	MEB2016Z	MEB2016ZU	579.000,00
22"	14"	MEB2214ZB	MEB2214Z	MEB2214ZU	603.000,00
22"	16"	MEB2216ZB	MEB2216Z	MEB2216ZU	603.000,00
22"	18"	MEB2218ZB	MEB2218Z	MEB2218ZU	618.000,00
24"	14"	MEB2414ZB	MEB2414Z	MEB2414ZU	634.000,00
24"	16"	MEB2416ZB	MEB2416Z	MEB2416ZU	634.000,00
Floor Toms					
13"	12"	MEF1312B	MEF1312	MEF1312U	319.000,00
14"	12"	MEF1412B	MEF1412	MEF1412U	336.000,00
14"	14"	MEF1414B	MEF1414	MEF1414U	336.000,00
16"	14"	MEF1614B	MEF1614	MEF1614U	370.000,00
16"	16"	MEF1616B	MEF1616	MEF1616U	370.000,00
18"	16"	MEF1816B	MEF1816	MEF1816U	407.000,00
Tom Toms					
8"	6"	MET0806B	MET0806	MET0806U	204.000,00
8"	7"	MET0807B	MET0807	MET0807U	204.000,00
10"	6.5"	MET1065B	MET1065	MET1065U	224.000,00
10"	7"	MET1007B	MET1007	MET1007U	224.000,00
10"	8"	MET1008B	MET1008	MET1008U	224.000,00
10"	9"	MET1009B	MET1009	MET1009U	224.000,00
12"	7"	MET1207B	MET1207	MET1207U	251.000,00
12"	8"	MET1208B	MET1208	MET1208U	251.000,00
12"	9"	MET1209B	MET1209	MET1209U	251.000,00
12"	10"	MET1210B	MET1210	MET1210U	251.000,00
13"	7.5"	MET1375B	MET1375	MET1375U	284.000,00
13"	9"	MET1309B	MET1309	MET1309U	284.000,00
13"	10"	MET1310B	MET1310	MET1310U	284.000,00
13"	11"	MET1311B	MET1311	MET1311U	284.000,00
14"	10"	MET1410B	MET1410	MET1410U	312.000,00
14"	11"	MET1411B	MET1411	MET1411U	312.000,00
14"	12"	MET1412B	MET1412	MET1412U	312.000,00
Snare Drums					
13"	6"	MES136B	MES136	MES136U	238.000,00
14"	5.5"	MES1455B	MES1455	MES1455U	238.000,00
14"	6.5"	MES1465B	MES1465	MES1465U	246.000,00
14"	8"	MES148B	MES148	MES148U	292.000,00

SPECIFICATIONS

Shells

(LEWB/LNWB/LRWB)
 TT/FT: 5mm, 6ply Maple + 1 outer ply Pacific Walnut
 BD/SD: 7mm, 8ply Maple + 1 outer ply Pacific Walnut

(VGLM/VTBV)

TT/FT: 5mm, 6ply Maple + 1 outer ply Movingui
 BD/SD: 7mm, 8ply Maple + 1 outer ply Movingui

- Star-Cast Mounting System
- Quick-Lock Tom Bracket
- EVANS® Heads
- Die-Cast Hoops
- Hold Tight™ Washers
- Claw Hooks w/ Rubber Spacers
- Cushioned Floor Tom Legs

OPTION



MODEL NUMBER SYSTEM - Individual Drums

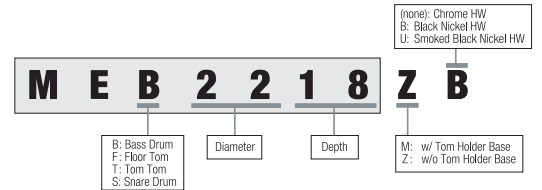

FINISHES (Lacquer)



STARCLASSIC MAPLE

Lacquer Finishes



COLOR Molten Electric Blue Burst **MEB**
w/ black nickel hardware

MA42TZBNS basic kit

including:

- 22"x16" bass drum
- 10"x7" tom tom
- 12"x8" tom tom
- 16"x16" floor tom

[add-on]

- 14"x6.5" snare drum

KIT CONFIGURATIONS LIST

[22" BD 3pc Shell Kit]

MA32CZS	w/ Chrome Hardware	1.155.000,00
MA32CZBNS	w/ Black Nickel Hardware	1.155.000,00
MA32CZUS	w/ Smoked Black Nickel Hardware	1.155.000,00

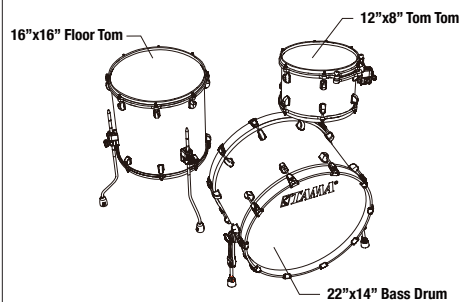

[22" BD 4pc Shell Kit]

MA42TZS	w/ Chrome Hardware	1.347.000,00
MA42TZBNS	w/ Black Nickel Hardware	1.347.000,00
MA42TZUS	w/ Smoked Black Nickel Hardware	1.347.000,00

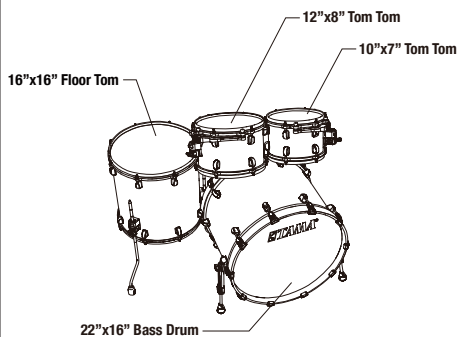

INDIVIDUAL MODEL NUMBERS

Diameter	Depth	Model No.			
		Black Nickel	Chrome	Smoked Black Nickel	
Bass Drum *To order Bass Drum w/ Tom Holder Base, Please substitute "Z" with "M". Ex MAB2218Z → MAB2218M					
16"	12"	MAB1612ZBN	MAB1612Z	MAB1612ZU	535.000,00
18"	14"	MAB1814ZBN	MAB1814Z	MAB1814ZU	562.000,00
20"	14"	MAB2014ZBN	MAB2014Z	MAB2014ZU	579.000,00
20"	16"	MAB2016ZBN	MAB2016Z	MAB2016ZU	579.000,00
22"	14"	MAB2214ZBN	MAB2214Z	MAB2214ZU	603.000,00
22"	16"	MAB2216ZBN	MAB2216Z	MAB2216ZU	603.000,00
22"	18"	MAB2218ZBN	MAB2218Z	MAB2218ZU	618.000,00
24"	14"	MAB2414ZBN	MAB2414Z	MAB2414ZU	634.000,00
24"	16"	MAB2416ZBN	MAB2416Z	MAB2416ZU	634.000,00
Floor Toms					
13"	12"	MAF1312BN	MAF1312	MAF1312U	319.000,00
14"	12"	MAF1412BN	MAF1412	MAF1412U	336.000,00
14"	14"	MAF1414BN	MAF1414	MAF1414U	336.000,00
16"	14"	MAF1614BN	MAF1614	MAF1614U	370.000,00
16"	16"	MAF1616BN	MAF1616	MAF1616U	370.000,00
18"	16"	MAF1816BN	MAF1816	MAF1816U	407.000,00
Tom Toms					
8"	6"	MAT0806BN	MAT0806	MAT0806U	204.000,00
8"	7"	MAT0807BN	MAT0807	MAT0807U	204.000,00
10"	6.5"	MAT1065BN	MAT1065	MAT1065U	224.000,00
10"	7"	MAT1007BN	MAT1007	MAT1007U	224.000,00
10"	8"	MAT1008BN	MAT1008	MAT1008U	224.000,00
10"	9"	MAT1009BN	MAT1009	MAT1009U	224.000,00
12"	7"	MAT1207BN	MAT1207	MAT1207U	251.000,00
12"	8"	MAT1208BN	MAT1208	MAT1208U	251.000,00
12"	9"	MAT1209BN	MAT1209	MAT1209U	251.000,00
12"	10"	MAT1210BN	MAT1210	MAT1210U	251.000,00
13"	7.5"	MAT1375BN	MAT1375	MAT1375U	284.000,00
13"	9"	MAT1309BN	MAT1309	MAT1309U	284.000,00
13"	10"	MAT1310BN	MAT1310	MAT1310U	284.000,00
13"	11"	MAT1311BN	MAT1311	MAT1311U	284.000,00
14"	10"	MAT1410BN	MAT1410	MAT1410U	312.000,00
14"	11"	MAT1411BN	MAT1411	MAT1411U	312.000,00
14"	12"	MAT1412BN	MAT1412	MAT1412U	312.000,00
Snare Drums					
13"	6"	MAS136BN	MAS136	MAS136U	238.000,00
14"	5.5"	MAS1455BN	MAS1455	MAS1455U	238.000,00
14"	6.5"	MAS1465BN	MAS1465	MAS1465U	246.000,00
14"	8"	MAS148BN	MAS148	MAS148U	292.000,00

SPECIFICATIONS

Shells
All Maple Shell
TT/FT: 5mm, 6ply
BD/SD: 7mm, 8ply

Star-Cast Mounting System
Quick-Lock Tom Bracket
EVANS® Heads
Die-Cast Hoops
Hold Tight™ Washers
Claw Hooks w/ Rubber Spacers
Cushioned Floor Tom Legs

OPTION



MODEL NUMBER SYSTEM - Individual Drums

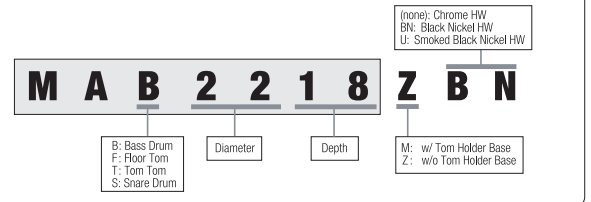

FINISHES (Lacquer)

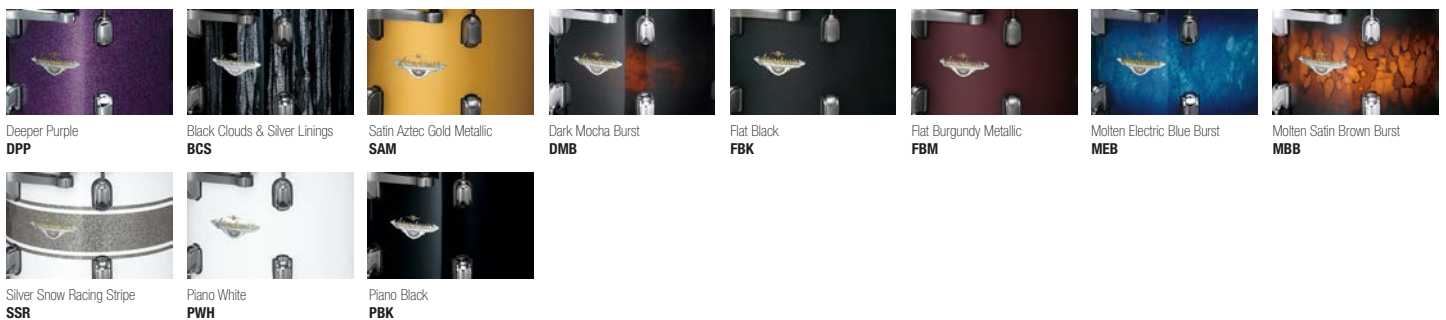

STARCLASSIC MAPLE

Duracover Wrap Finishes



COLOR Red Oyster
w/ black nickel hardware **ROY**

MR42TZBNS basic kit

including:
22"x16" bass drum
10"x7" tom tom
12"x8" tom tom
16"x16" floor tom

[add-on]
14"x6.5" snare drum

KIT CONFIGURATIONS LIST

[22" BD 3pc Shell Kit]

MR32CZS	w/ Chrome Hardware	1.078.000,00
MR32CZBNS	w/ Black Nickel Hardware	1.078.000,00
MR32CZUS	w/ Smoked Black Nickel Hardware	1.078.000,00

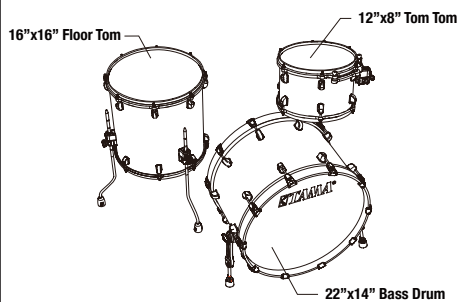

[22" BD 4pc Shell Kit]

MR42TZS	w/ Chrome Hardware	1.270.000,00
MR42TZBNS	w/ Black Nickel Hardware	1.270.000,00
MR42TZUS	w/ Smoked Black Nickel Hardware	1.270.000,00

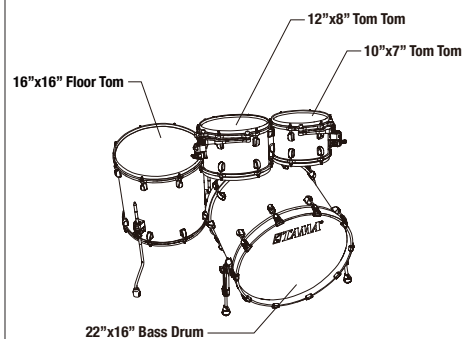

INDIVIDUAL MODEL NUMBERS

Diameter	Depth	Model No.			
		Black Nickel	Chrome	Smoked Black Nickel	
Bass Drum *To order Bass Drum w/ Tom Holder Base, Please substitute "Z" with "M". Ex MRB2218Z → MRB2218M					
16"	12"	MRB1612ZBN	MRB1612Z	MRB1612ZU	493.000,00
18"	14"	MRB1814ZBN	MRB1814Z	MRB1814ZU	517.000,00
20"	14"	MRB2014ZBN	MRB2014Z	MRB2014ZU	533.000,00
20"	16"	MRB2016ZBN	MRB2016Z	MRB2016ZU	533.000,00
22"	14"	MRB2214ZBN	MRB2214Z	MRB2214ZU	556.000,00
22"	16"	MRB2216ZBN	MRB2216Z	MRB2216ZU	556.000,00
22"	18"	MRB2218ZBN	MRB2218Z	MRB2218ZU	569.000,00
24"	14"	MRB2414ZBN	MRB2414Z	MRB2414ZU	583.000,00
24"	16"	MRB2416ZBN	MRB2416Z	MRB2416ZU	583.000,00
Floor Toms					
13"	12"	MRF1312BN	MRF1312	MRF1312U	294.000,00
14"	12"	MRF1412BN	MRF1412	MRF1412U	310.000,00
14"	14"	MRF1414BN	MRF1414	MRF1414U	310.000,00
16"	14"	MRF1614BN	MRF1614	MRF1614U	341.000,00
16"	16"	MRF1616BN	MRF1616	MRF1616U	341.000,00
18"	16"	MRF1816BN	MRF1816	MRF1816U	375.000,00
Tom Toms					
8"	6"	MRT0806BN	MRT0806	MRT0806U	188.000,00
8"	7"	MRT0807BN	MRT0807	MRT0807U	188.000,00
10"	6.5"	MRT1065BN	MRT1065	MRT1065U	206.000,00
10"	7"	MRT1007BN	MRT1007	MRT1007U	206.000,00
10"	8"	MRT1008BN	MRT1008	MRT1008U	206.000,00
10"	9"	MRT1009BN	MRT1009	MRT1009U	206.000,00
12"	7"	MRT1207BN	MRT1207	MRT1207U	231.000,00
12"	8"	MRT1208BN	MRT1208	MRT1208U	231.000,00
12"	9"	MRT1209BN	MRT1209	MRT1209U	231.000,00
12"	10"	MRT1210BN	MRT1210	MRT1210U	231.000,00
13"	7.5"	MRT1375BN	MRT1375	MRT1375U	261.000,00
13"	9"	MRT1309BN	MRT1309	MRT1309U	261.000,00
13"	10"	MRT1310BN	MRT1310	MRT1310U	261.000,00
13"	11"	MRT1311BN	MRT1311	MRT1311U	261.000,00
14"	10"	MRT1410BN	MRT1410	MRT1410U	287.000,00
14"	11"	MRT1411BN	MRT1411	MRT1411U	287.000,00
14"	12"	MRT1412BN	MRT1412	MRT1412U	287.000,00
Snare Drums					
13"	6"	MRS136BN	MRS136	MRS136U	219.000,00
14"	5.5"	MRS1455BN	MRS1455	MRS1455U	219.000,00
14"	6.5"	MRS1465BN	MRS1465	MRS1465U	227.000,00
14"	8"	MRS148BN	MRS148	MRS148U	273.000,00

SPECIFICATIONS

Shells
All Maple Shell
TT/FT: 5mm, 6ply
BD/SD: 7mm, 8ply

Star-Cast Mounting System
Quick-Lock Tom Bracket
EVANS® Heads
Die-Cast Hoops
Hold Tight™ Washers
Claw Hooks w/ Rubber Spacers
Cushioned Floor Tom Legs

OPTION



MODEL NUMBER SYSTEM - Individual Drums

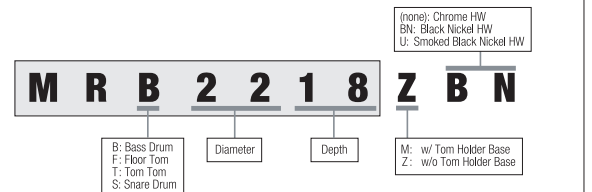

FINISHES (Duracover Wrap)



Blue and White Oyster
BWO



Red Oyster
ROY



Charcoal Swirl
CCL



Sky Blue Swirl
SLW



Turquoise Pearl
TOP

STARCLASSIC WALNUT/BIRCH

Lacquer Finishes

Exploring limitless possibilities, our result in the wake of countless experimentation came in the form of the Hybrid Shell Walnut/Birch: combining the superior quality warmth and mid to low frequency tone of the increasingly popular and truly unique Walnut, with the well-defined and uncompromisingly solid attack of Birch.

Whilst we successfully preserved their unique sonic trademarks, the characteristics of both Walnut and Birch blend to persuade a very focused sound that would define itself with great distinction within a musical ensemble; married with controlled sustain and clarity; all sealed with an undeniably palpable feeling of warmth and resonance when performed.



COLOR Molten Blue Ice Fade

MBI

WBS52RZS basic kit

including:

- 22"x16" bass drum
- 10"x7" tom tom
- 12"x8" tom tom
- 14"x12" floor tom
- 16"x14" floor tom
- MC69 single tom attachments (x2)

[add-on]

- 14"x6.5" snare drum

KIT CONFIGURATIONS LIST

[20" BD 3pc Shell Kit]

WBS30RS

w/ Chrome Hardware

712.000,00

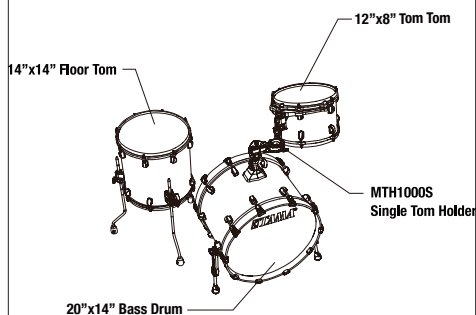

[22" BD 3pc Shell Kit]

WBS32RZS

w/ Chrome Hardware

712.000,00

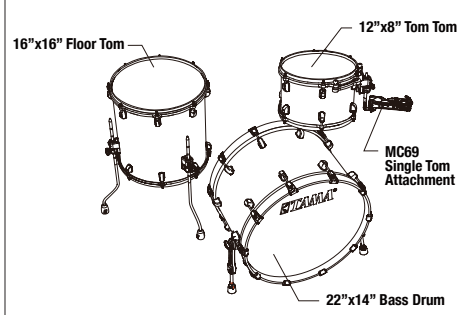

[22" BD 4pc Shell Kit]

WBS42S

w/ Chrome Hardware

885.000,00

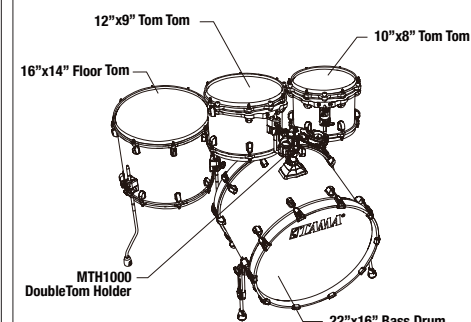

[22" BD 5pc Shell Kit]

WBS52RZS

w/ Chrome Hardware

1.116.000,00

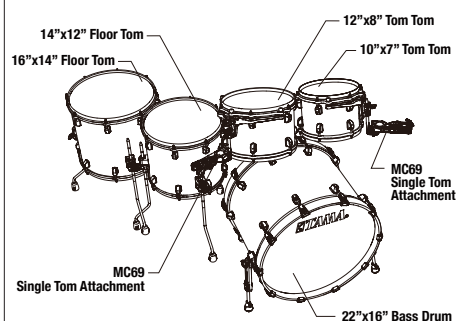

INDIVIDUAL MODEL NUMBERS

Diameter	Depth	Model No.	
Bass Drums			
16"	12"	WBSB16HZ	462.000,00
18"	14"	WBSB18RZ	486.000,00
20"	14"	WBSB20RZ	505.000,00
20"	16"	WBSB20DZ	505.000,00
22"	14"	WBSB22RZ	531.000,00
22"	16"	WBSB22DZ	531.000,00
22"	18"	WBSB22EZ	561.000,00
24"	16"	WBSB24DZ	569.000,00
Floor Toms			
13"	12"	WBSF13R	253.000,00
14"	12"	WBSF14A	266.000,00
14"	14"	WBSF14D	266.000,00
16"	14"	WBSF16A	283.000,00
16"	16"	WBSF16D	283.000,00
18"	16"	WBSF18D	312.000,00
Tom Toms			
8"	6"	WBST8H	168.000,00
8"	7"	WBST8A	168.000,00
10"	6.5"	WBST10H	182.000,00
10"	7"	WBST10R	182.000,00
10"	8"	WBST10A	182.000,00
12"	7"	WBST12H	204.000,00
12"	8"	WBST12R	204.000,00
12"	9"	WBST12A	204.000,00
13"	7.5"	WBST13H	230.000,00
13"	9"	WBST13R	230.000,00
13"	10"	WBST13A	230.000,00
14"	11"	WBST14A	251.000,00
14"	12"	WBST14D	251.000,00
Snare Drums			
13"	6"	WBSS136	173.000,00
14"	5.5"	WBSS55	177.000,00
14"	6.5"	WBSS65	181.000,00
14"	8"	WBSS148	208.000,00

MODEL NUMBER SYSTEM - Individual Drums

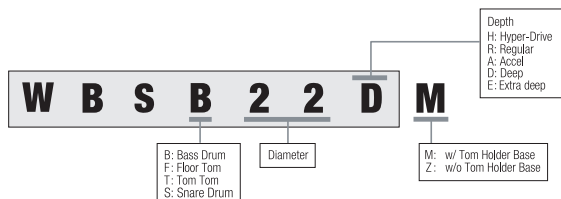

SPECIFICATIONS

Shells

TT/FT/SD: 6mm, 4ply European Birch + 2 inner ply American Black Walnut
 BD: 8mm, 5ply European Birch + 2 inner ply American Black Walnut

Star-Cast Mounting System

Quick-Lock Tom Bracket

EVANS® Heads

Claw Hooks w/ Rubber Spacers

Cushioned Floor Tom Legs

Die-Cast Hoops

FINISHES (Lacquer)



Lacquer Ocean Blue Ripple
LOR



Lacquer Phantasm Oyster
LPO



Lacquer Shamrock Oyster
LSO



Satin Purple Atmosphere Fade
SAF



Satin Sapphire Fade
SPF



Molten Blue Ice Fade
MBI



Molten Dark Raspberry Fade
MDR



Molten Brown Burst
MBR



Piano Black
PBK

STARCLASSIC WALNUT/BIRCH

Duracover Wrap Finishes



COLOR Turquoise Pearl **TQP**

WBR32RZS basic kit

including:
 22"x14" bass drum
 12"x8" tom tom
 16"x16" floor tom
 MC69 single tom attachment

[add-on]
 14"x6.5" snare drum

KIT CONFIGURATIONS LIST

[20" BD 3pc Shell Kit]

WBR30RS w/ Chrome Hardware **712.000,00**

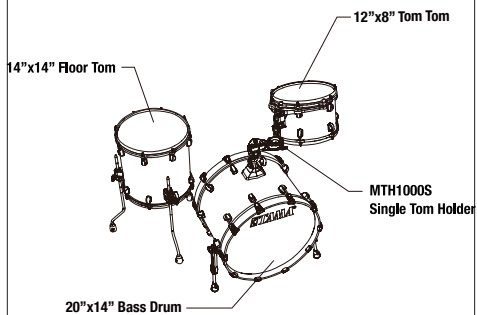

[22" BD 3pc Shell Kit]

WBR32RZS w/ Chrome Hardware **712.000,00**

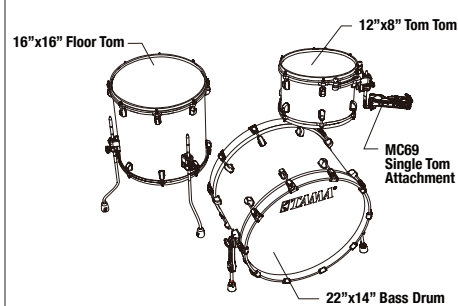

[22" BD 4pc Shell Kit]

WBR42S w/ Chrome Hardware **885.000,00**

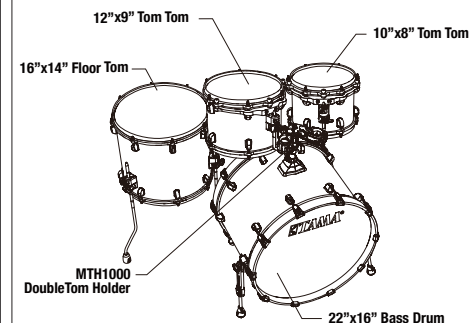

[22" BD 5pc Shell Kit]

WBR52RZS w/ Chrome Hardware **1.116.000,00**

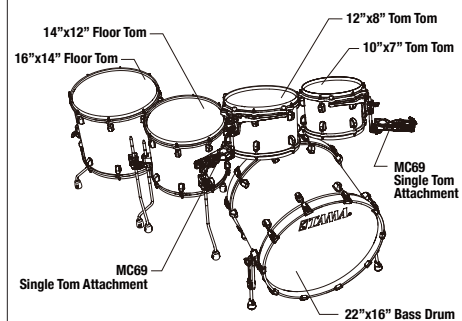

INDIVIDUAL MODEL NUMBERS

Diameter	Depth	Model No.		
Bass Drums *To order Bass Drum w/ Tom Holder Base, Please substitute "Z" with "M". Ex WBRB22DZ → WBRB22DM				
16"	12"	WBRB16HZ		462.000,00
18"	14"	WBRB18RZ		486.000,00
20"	14"	WBRB20RZ		505.000,00
20"	16"	WBRB20DZ		505.000,00
22"	14"	WBRB22RZ		531.000,00
22"	16"	WBRB22DZ		531.000,00
22"	18"	WBRB22EZ		561.000,00
24"	16"	WBRB24DZ		569.000,00
Floor Toms				
13"	12"	WBRF13R		253.000,00
14"	12"	WBRF14A		266.000,00
14"	14"	WBRF14D		266.000,00
16"	14"	WBRF16A		283.000,00
16"	16"	WBRF16D		283.000,00
18"	16"	WBRF18D		312.000,00
Tom Toms				
8"	6"	WBRT8H		168.000,00
8"	7"	WBRT8A		168.000,00
10"	6.5"	WBRT10H		182.000,00
10"	7"	WBRT10R		182.000,00
10"	8"	WBRT10A		182.000,00
12"	7"	WBRT12H		204.000,00
12"	8"	WBRT12R		204.000,00
12"	9"	WBRT12A		204.000,00
13"	7.5"	WBRT13H		230.000,00
13"	9"	WBRT13R		230.000,00
13"	10"	WBRT13A		230.000,00
14"	11"	WBRT14A		251.000,00
14"	12"	WBRT14D		251.000,00
Snare Drums				
13"	6"	WBRS136		173.000,00
14"	5.5"	WBRS55		177.000,00
14"	6.5"	WBRS65		181.000,00
14"	8"	WBRS148		208.000,00

MODEL NUMBER SYSTEM - Individual Drums

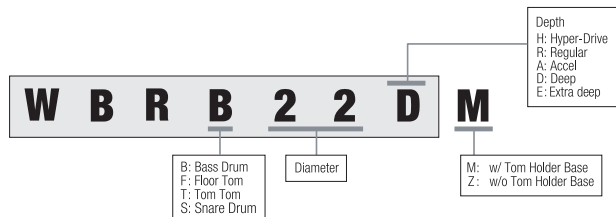

SPECIFICATIONS

Shells

TT/FT/SD: 6mm, 4ply European Birch + 2 inner ply American Black Walnut
 BD: 8mm, 5ply European Birch + 2 inner ply American Black Walnut

Star-Cast Mounting System

Claw Hooks w/ Rubber Spacers

Quick-Lock Tom Bracket

Cushioned Floor Tom Legs

EVANS® Heads

Die-Cast Hoops

FINISHES (Duracover Wrap)

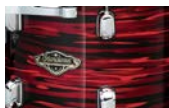

Red Oyster
ROY



Vintage Marine Pearl
VMP



Turquoise Pearl
TQP



Charcoal Onyx
CCO

STARCLASSIC PERFORMER

Lacquer Finishes

Tama's newest Starclassic Performer series centers on the newest Tama hybrid shell – maple/birch – to offer drummers a complex, powerful and expressive sound supported by rugged Starclassic performance. Tama's Starclassic Performer series evolves the Starclassic legacy to provide a unique Tama sonic component that redefines the art of professional drum set sound and expression at an undeniable value.



COLOR Sky Blue Aurora

SKA

MBS52RZS basic kit

including:

- 22"x16" bass drum
- 10"x7" tom tom
- 12"x8" tom tom
- 14"x12" floor tom
- 16"x14" floor tom
- MC69 single tom attachments (x2)

[add-on]

- 14"x6.5" snare drum

KIT CONFIGURATIONS LIST

[22" BD 4pc Shell Kit]

MBS42S w/ Chrome Hardware

577.000,00

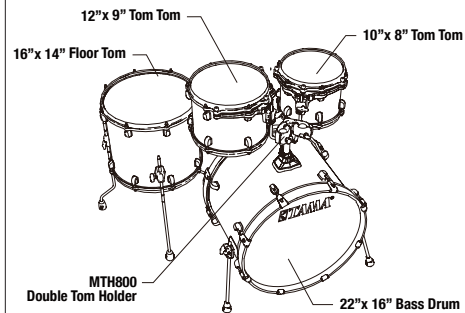

[22" BD 5pc Shell Kit]

MBS52RZS w/ Chrome Hardware

693.000,00

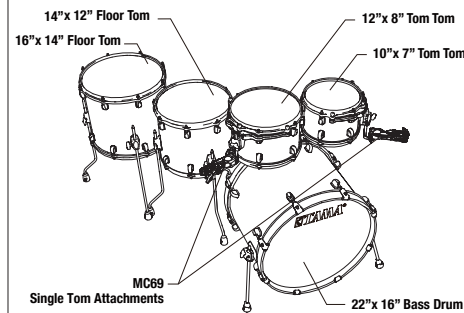

INDIVIDUAL MODEL NUMBERS

Diameter	Depth	Model No.	
Bass Drums *To order Bass Drum w/ Tom Holder Base, Please substitute "Z" with "M". Ex MBSB22DZ → MBSB22DM			
18"	14"	MBSB18RZ	310.000,00
20"	14"	MBSB20RZ	322.000,00
22"	16"	MBSB22DZ	338.000,00
22"	18"	MBSB22EZ	359.000,00
24"	16"	MBSB24DZ	379.000,00
Floor Toms			
14"	12"	MBSF14A	192.000,00
14"	14"	MBSF14D	192.000,00
16"	14"	MBSF16A	212.000,00
18"	16"	MBSF18D	233.000,00
Tom Toms			
8"	6"	MBST8H	118.000,00
8"	7"	MBST8A	118.000,00
10"	7"	MBST10R	131.000,00
10"	8"	MBST10A	131.000,00
12"	8"	MBST12R	142.000,00
12"	9"	MBST12A	142.000,00
13"	9"	MBST13R	167.000,00
13"	10"	MBST13A	167.000,00
Snare Drums			
14"	5.5"	MBSS55	127.000,00
14"	6.5"	MBSS65	131.000,00

MODEL NUMBER SYSTEM - Individual Drums

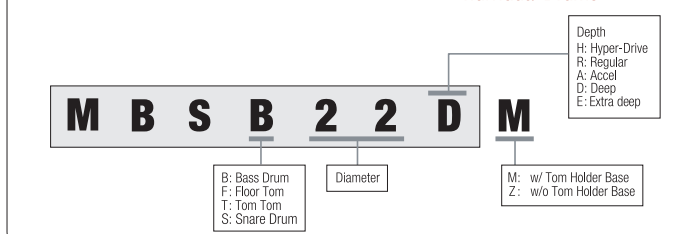

SPECIFICATIONS

Shells

TT/FT/SD: 6mm, 4ply Birch + 2 inner ply Maple
BD: 7mm, 5ply Birch + 2 inner ply Maple

Star-Cast Mounting System

Claw Hooks w/ Rubber Spacers

Cushioned Floor Tom Legs

EVANS® Heads

Die-Cast Hoops

FINISHES (Lacquer)



Caramel Aurora
CAR



Sky Blue Aurora
SKA



Molten Steel Blue Burst
MSL



Dark Cherry Fade
DCF



Piano Black
PBK

SUPERSTAR CLASSIC

Exotic Finishes

For more than forty years, the Superstar name has stood for groundbreaking design, superior build quality, sterling tone, and clear projection. Superstar Classic once again upholds tradition by raising the bar for discerning drummers—and remarkably—does it while also lowering the price. Drawing on Superstar of the past, its classic TAMA T-shape badge and streamlined low-mass single lugs point to the simpler state of art of the 70's, while the ingenious Star-Mount system and the thinner gauge 100% maple shells eclipse anything in its class.



COLOR Caribbean Laceybark Pine Fade PCLP

CL72RS 7pc basic kit

including:
 22"x16" bass drum
 8"x6" tom tom
 10"x7" tom tom
 12"x8" tom tom
 14"x12" floor tom
 16"x14" floor tom
 14"x6.5" snare drum
 MTH600 double tom holder
 MC69 single tom attachment

KIT CONFIGURATIONS LIST

[22" BD 5pc Shell Kit]

CL52KRS		404.000,00
CL52KR	w/SM5W hardware pack	508.000,00

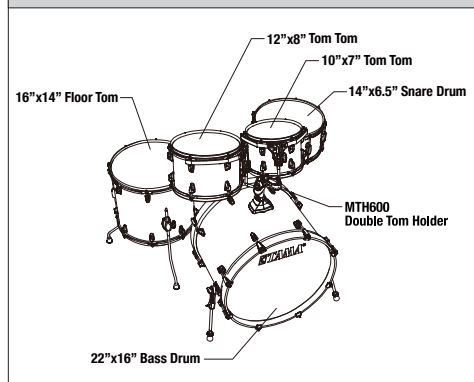

[22" BD 7pc Shell Kit]

CL72RS		589.000,00
CL72R	w/ SM5W hardware pack	693.000,00

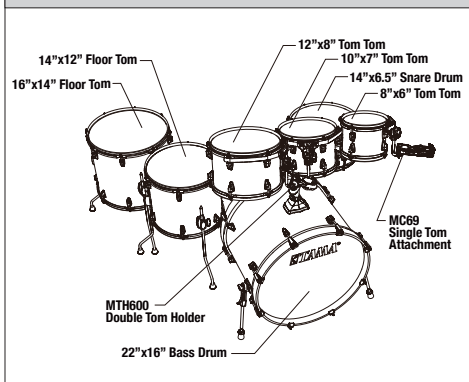

INDIVIDUAL MODEL NUMBERS

Diameter	Depth	Model No.	
Bass Drums			
18" (w/ bass drum lifter)	14"	CLB18RL	211.000,00
20"	16"	CLB20D	227.000,00
22"	16"	CLB22D	242.000,00
24"	16"	CLB24D	261.000,00
Floor Toms			
14"	12"	CLF14A	119.000,00
14"	14"	CLF14D	119.000,00
16"	14"	CLF16A	134.000,00
18"	16"	CLF18D	150.000,00
Tom Toms			
8"	6"	CLT8H	77.000,00
10"	7"	CLT10R	84.000,00
12"	8"	CLT12R	96.000,00
13"	9"	CLT13R	107.000,00
Snare Drums			
14"	5"	CLS145	77.000,00
14"	6.5"	CLS1465	80.000,00

SPECIFICATIONS

Shells

TT/FT/SD: 5mm 4ply Maple + 2 outer ply Lacebark Pine
 BD: 7mm 6ply Maple + 2 outer ply Lacebark Pine

Star-Mount System

Low-Mass Lugs

Power Craft II Drum Heads

FINISHES (Lacquer)



Caribbean Lacebark Pine Fade
PCLP



Gloss Garnet Lacebark Pine
PGGP



Gloss Sapphire Lacebark Pine
PGHP



Gloss Java Lacebark Pine
PGJP



Gloss Lacebark Pine Fade
PGLP

SUPERSTAR CLASSIC

Lacquer Finishes



COLOR Gloss Natural Blonde **GNL**

CL52KRS 5pc basic kit

including:
 22"x16" bass drum
 10"x7" tom tom
 12"x8" tom tom
 16"x14" floor tom
 14"x6.5" snare drum
 MTH600 double tom holder

KIT CONFIGURATIONS LIST

[22" BD 3pc Shell Kit] **NEW**

CL32RZS 308.000,00
CL32RZ w/SM5W hardware pack 412.000,00

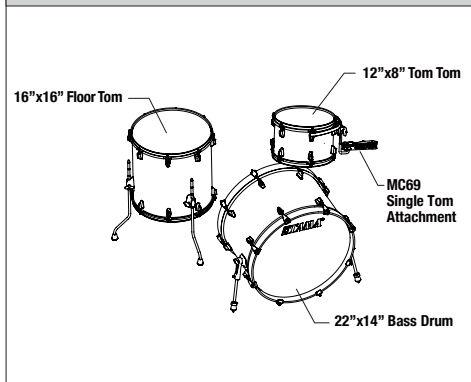

[20" BD 5pc Shell Kit]

CL50RS 404.000,00
CL50R w/SM5W hardware pack 508.000,00

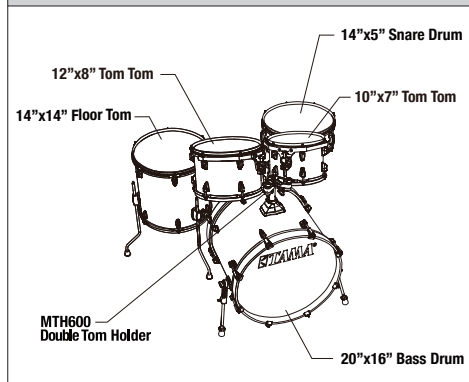

[22" BD 5pc Shell Kit]

CL52KRS 404.000,00
CL52KR w/SM5W hardware pack 508.000,00

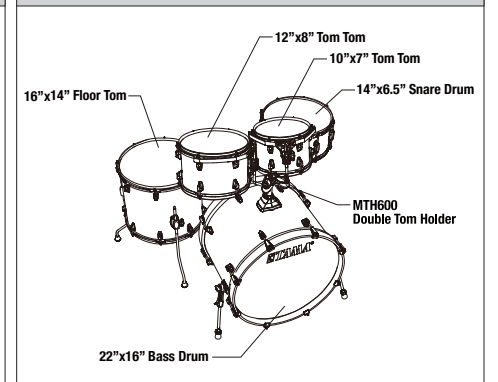

INDIVIDUAL MODEL NUMBERS

Diameter	Depth	Model No.	
Bass Drums			
18"(w/ bass drum lifter)	14"	CLB18RL	211.000,00
20"	16"	CLB20D	227.000,00
22"	14"	CLB22RZ	242.000,00
22"	16"	CLB22D	242.000,00
24"	16"	CLB24D	261.000,00
Floor Toms			
14"	12"	CLF14A	119.000,00
14"	14"	CLF14D	119.000,00
16"	14"	CLF16A	134.000,00
16"	16"	CLF16D	134.000,00
18"	16"	CLF18D	150.000,00
Tom Toms			
8"	6"	CLT8H	77.000,00
10"	7"	CLT10R	84.000,00
12"	8"	CLT12R	96.000,00
13"	9"	CLT13R	107.000,00
Snare Drums			
14"	5"	CLS145	77.000,00
14"	6.5"	CLS1465	80.000,00

SPECIFICATIONS

Shells

TT/FT/SD: 5mm 4ply Maple + 2 outer ply Lacebark Pine
 BD: 7mm 6ply Maple + 2 outer ply Lacebark Pine

Star-Mount System

Low-Mass Lugs

Power Craft II Drum Heads

FINISHES (Lacquer)



Gloss Natural Blonde
GNL



NEW

Blue Lacquer Burst
BAB



Coffee Fade
CFF



Tangerine Lacquer Burst
TLB



Transparent Black Burst
TPB

SUPERSTAR CLASSIC

Unicolor Wrap Finishes



COLOR Ice Ash Wrap **ICA**

CK52KRS 5pc basic kit

including:
 22"x16" bass drum
 10"x7" tom tom
 12"x8" tom tom
 16"x14" floor tom
 14"x6.5" snare drum
 MTH600 double tom holder

KIT CONFIGURATIONS LIST

[22" BD 3pc Shell Kit] **NEW**

CK32RZS 277.000,00
CK32RZ w/SM5W hardware pack 381.000,00

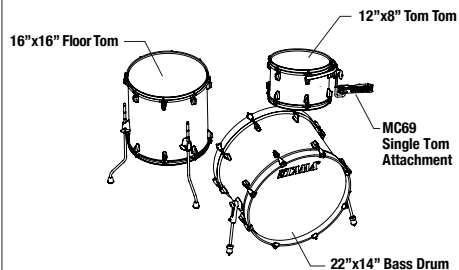

[20" BD 5pc Shell Kit]

CK50RS 373.000,00
CK50R w/SM5W hardware pack 477.000,00

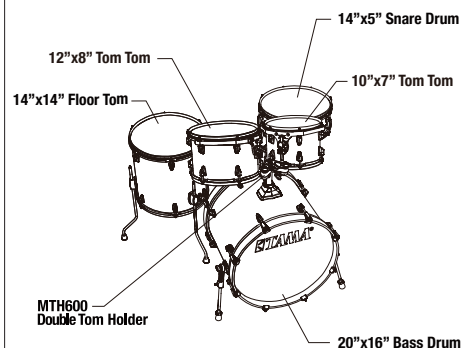

[22" BD 5pc Shell Kit]

CK52KRS 373.000,00
CK52KR w/SM5W hardware pack 477.000,00

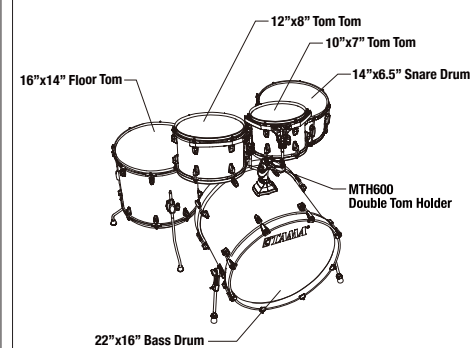

INDIVIDUAL MODEL NUMBERS

Diameter	Depth	Model No.	
Bass Drums			
18" (w/ bass drum lifter)	14"	CKB18RL	196.000,00
20"	16"	CKB20D	211.000,00
22"	14"	CKB22RZ	223.000,00
22"	16"	CKB22D	223.000,00
24"	16"	CKB24D	238.000,00
Floor Toms			
14"	12"	CKF14A	111.000,00
14"	14"	CKF14D	111.000,00
16"	14"	CKF16A	127.000,00
16"	16"	CKF16D	134.000,00
18"	16"	CKF18D	134.000,00
Tom Toms			
8"	6"	CKT8H	69.000,00
10"	7"	CKT10R	77.000,00
12"	8"	CKT12R	80.000,00
13"	9"	CKT13R	88.000,00
Snare Drums			
14"	5"	CKS145	69.000,00
14"	6.5"	CKS1465	73.000,00

SPECIFICATIONS

Shells

TT/FT/SD: 5mm 4ply Maple + 2 outer ply Lacebark Pine
 BD: 7mm 6ply Maple + 2 outer ply Lacebark Pine

Star-Mount System

Low-Mass Lugs

Power Craft II Drum Heads

FINISHES (Unicolor Wrap)



Ice Ash Wrap
ICA



Natural Ebony Tiger Wrap
NET



Indigo Sparkle
ISP



Midnight Gold Sparkle
MGD

IMPERIALSTAR

Unicolor Wrap Finish w/Black Nickel Shell Hardware



COLOR Blacked Out Black **BOB**

IP52H6WBN 22" Bass Drum 5pc basic kit

Drums:
22"x18" bass drum, 10"x7" & 12"x8" tom toms, 16"x14" floor tom, 14"x5" snare drum.

Hardware:
double tom holder, hi-hat stand, drum pedal, snare stand, boom cymbal stand, straight cymbal stand, drum throne.

[Meinl HCS Brass Cymbals]

All the kits come with Meinl HCS Brass 14" Hi-hat, 16" Crash & 20" Ride cymbals

KIT CONFIGURATIONS LIST

[20" BD 5pc Kit w/ Hardware & MEINL Cymbals]

NEW

423.000,00

IP50H6WBN

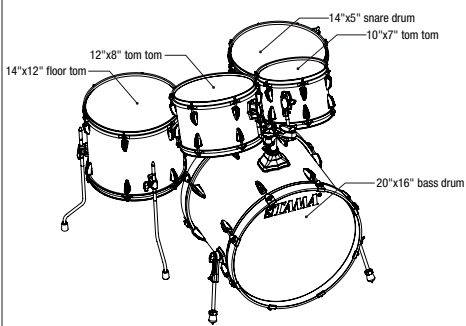

[22" BD 5pc Kit w/ Hardware & MEINL Cymbals]

423.000,00

IP52H6WBN

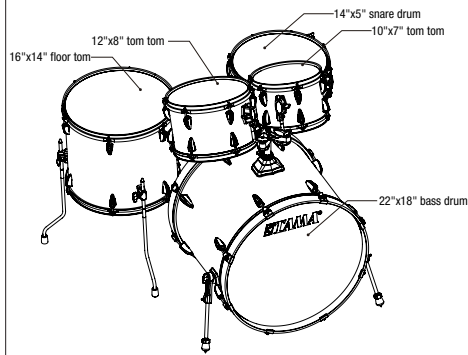

INDIVIDUAL MODEL NUMBERS

Diameter	Depth	Model No.	
Bass Drums			
18"	14"	IPB18RWB	126.000,00
20"	16"	IPB20DWB	135.000,00
22"	18"	IPB22EWB	140.000,00
Floor Toms			
14"	12"	IPF14AB	63.000,00
16"	14"	IPF16AB	70.000,00
18"	16"	IPF18DB	79.000,00
Tom Toms			
8"	7"	IPT8AB	42.000,00
10"	7"	IPT10RB	45.000,00
12"	8"	IPT12RB	46.000,00
13"	9"	IPT13RB	49.000,00
Snare Drums			
14"	5"	IPS145B	54.000,00
14"	6.5"	IPS1465B	56.000,00

SPECIFICATIONS

Shells

All Poplar Shell: 8mm 6ply

Omnisphere Tom Holder
Wood Bass Drum Hoops
Double Braced Hardware

FINISH (Unicolor Wrap)

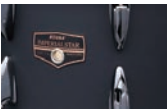

Blacked Out Black
BOB

IMPERIALSTAR

Unicolor Wrap Finishes w/Chrome Shell Hardware

In 2006, the Imperialstar line made its successful comeback, providing everything a drummer needs at an affordable price. Now, Imperialstar is refined to feature matching bass drum hoops, Stage Master double-braced hardware, and Iron Cobra 200 bass drum pedal.



COLOR Electric Yellow **ELY**

IP52H6W 22" Bass Drum 5pc basic kit

Drums:
22"x18" bass drum, 10"x7" & 12"x8" tom toms, 16"x14" floor tom, 14"x5" snare drum.

Hardware:
double tom holder, hi-hat stand, drum pedal, snare stand, boom cymbal stand, straight cymbal stand, drum throne.

[Meinl HCS Brass Cymbals]

All the kits come with Meinl HCS Brass 14" Hi-hat, 16" Crash & 20" Ride cymbals

KIT CONFIGURATIONS LIST

[18" BD 5pc Kit w/ Hardware & MEINL Cymbals]

IP58H6W 365.000,00

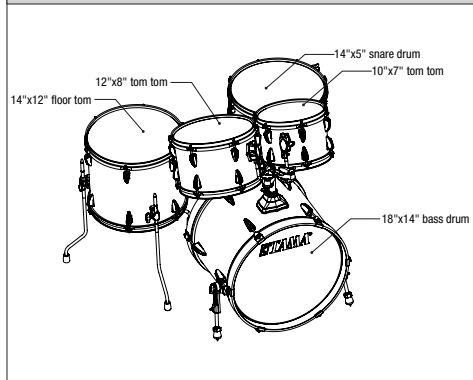

[20" BD 5pc Kit w/ Hardware & MEINL Cymbals]

IP50H6W 385.000,00

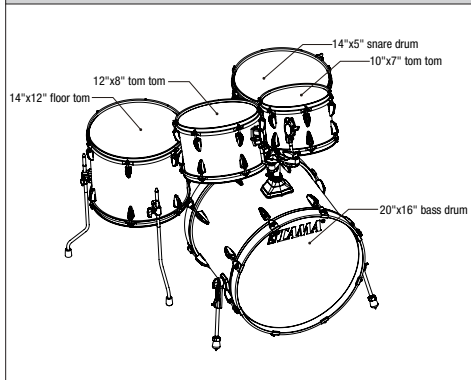

[22" BD 5pc Kit w/ Hardware & MEINL Cymbals]

IP52H6W 385.000,00

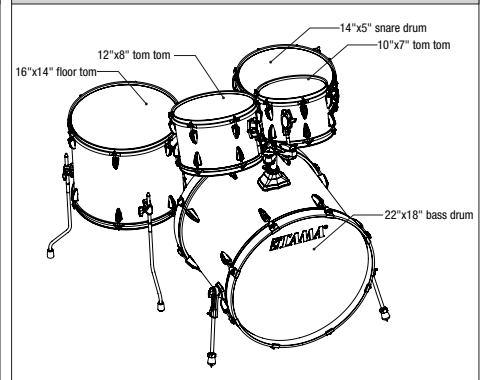

[22" BD 6pc Kit w/ Hardware & MEINL Cymbals]

IP62H6W 423.000,00

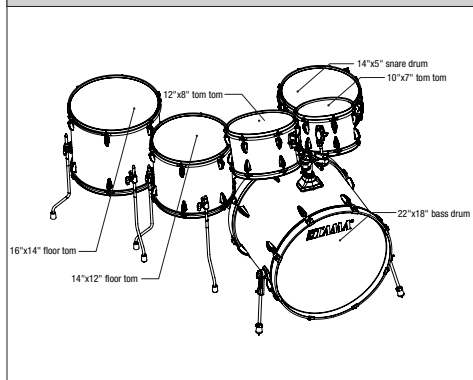

INDIVIDUAL MODEL NUMBERS

Diameter	Depth	Model No.	
Bass Drums			
18"	14"	IPB18RW	126.000,00
20"	16"	IPB20DW	135.000,00
22"	18"	IPB22EW	140.000,00
Floor Toms			
14"	12"	IPF14A	63.000,00
16"	14"	IPF16A	70.000,00
18"	16"	IPF18D	79.000,00
Tom Toms			
8"	7"	IPT8A	42.000,00
10"	7"	IPT10R	45.000,00
12"	8"	IPT12R	46.000,00
13"	9"	IPT13R	49.000,00
Snare Drums			
14"	5"	IPS145	54.000,00
14"	6.5"	IPS1465	56.000,00

SPECIFICATIONS

Shells

All Poplar Shell: 8mm 6ply

Omnisphere Tom Holder
Wood Bass Drum Hoops
Double Braced Hardware

FINISHES (Unicolor Wrap)



Coffee Teak Wrap
CTW



Burnt Red Mist
BRM



Electric Yellow
ELY



Hairline Black
HBK



Hairline Blue
HLB

STAGESTAR NEW

Unicolor Wrap Finishes

With 50 years of experience, TAMA knows what drummers really want. Which is why TAMA has the set you need, want and can afford no matter how long you've been playing drums or what budget you have to work with. Now TAMA has launched the affordable kit to ever incorporate many nice features – STAGESTAR. The new STAGESTAR kit comes with Omni-ball tom holder as well as double braced hardware for increased stability.



COLOR Candy Red Sparkle **CDS**

ST52H5 22" Bass Drum 5pc basic kit

Drums:

22" x 16" bass Drum, 10" x 8" tom tom, 12" x 9" tom tom, 16" x 15" floor tom, 14" x 5.5" snare drum.

Hardware:

double tom holder, hi-hat stand, drum pedal, snare stand, boom cymbal stand, drum throne.

[Meinl BCS Brass Cymbals]

All the kits come with Meinl BCS Brass 14" Hi-hat & 18" Crash-Ride cymbals

KIT CONFIGURATIONS LIST

[20" BD 5pc Kit w/ Hardware & MEINL Cymbals]

ST50H5 261.000,00

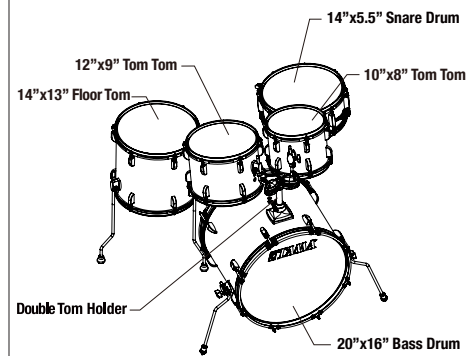

[22" BD 5pc Kit w/ Hardware & MEINL Cymbals]

ST52H5 261.000,00

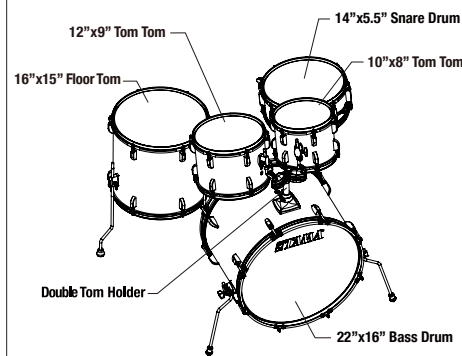

FINISHES (Unicolor Wrap)



Candy Red Sparkle
CDS

NEW

Sea Blue Mist
SEM

NEW

Black Night Sparkle
BNS

NEW

CLUB-JAM

Lacquer Finish

The "Club-JAM" Kit adopts some ideas from vintage kits, such as a cymbal holder mounted directly on the bass drum shell and curved bass drum spurs, further setting it apart from the typical compact kit.

Focused yet deep sound from Poplar shell is just right for small and intimate gigs. Its compact size and configuration make it ideal for working drummers, and it fits comfortably on just about any stage.



COLOR Satin Blonde **SBO**

LJL48S 18" Bass Drum 4pc basic kit

Drums:
18"x12" bass drum, 10"x7" tom tom, 14"x7" floor tom, 13"x5" snare drum.

Hardware:
single tom holder, cymbal holder.

KIT CONFIGURATION LIST

[18" BD 4pc Shell Kit]

LJL48S 242.000,00

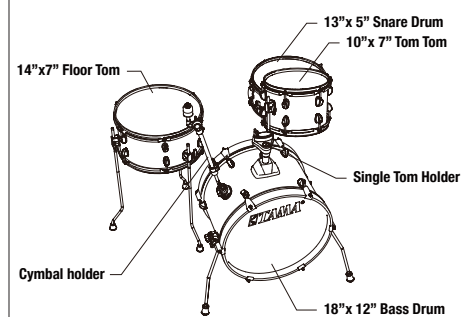

FINISH (Lacquer)



Satin Blonde
SBO

CLUB-JAM

Unicolor Wrap Finishes



COLOR Candy Apple Mist **CPM**

LJK48S 18" Bass Drum 4pc basic kit

Drums:
18"x12" bass drum, 10"x7" tom tom, 14"x7" floor tom, 13"x5" snare drum.

Hardware:
single tom holder, cymbal holder.

KIT CONFIGURATION LIST

[18" BD 4pc Shell Kit]

LJK48S 200.000,00

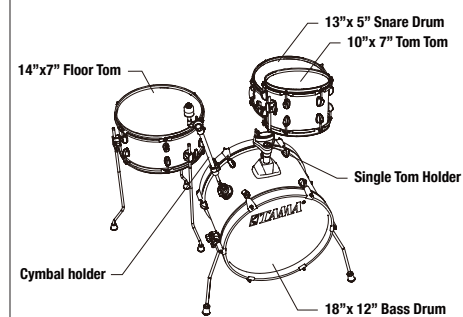

FINISHES (Unicolor Wrap)



Aqua Blue
AQB



Charcoal Mist
CCM



Candy Apple Mist
CPM



Cream Marble Wrap
CMW

CLUB-JAM MINI

Unicolor Wrap Finishes

The simple and sweet TAMA Club-JAM Mini kit is just a kick and snare. Its clear yet deep sound from the Poplar shell is just right for those small and intimate gigs. While its compact size and configuration fit comfortably at any small venue or street show. The Drum Bag Set for this kit (DSS28LJ) allows for smooth transportation (sold separately). If one needs to configure it as a regular drum kit, also available are add-on drums including the 10"x7" tom tom with attachment and a 14"x7" floor tom.



COLOR Candy Apple Mist **CPM**

LJK28S 18" Bass Drum 2pc basic kit

Drums:
18"x7" bass drum, 12"x5" snare drum.

LJKT10F14 Add-on pack

Add-on tom and floor tom package is sold separately.
10"x7" tom tom, 14"x7" floor tom, single tom attachment

84.000,00

KIT CONFIGURATION LIST

[18" BD 2pc Shell Kit]

LJK28S **131.000,00**

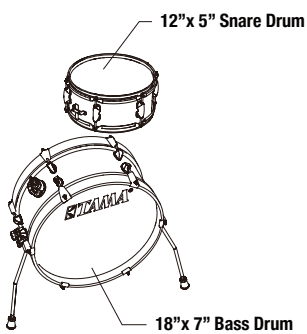

FINISHES (Unicolor Wrap)



Aqua Blue
AQB



Charcoal Mist
CCM



Candy Apple Mist
CPM

CLUB-JAM FLYER

Unicolor Wrap Finishes

The Club-JAM Flyer is the ultimate compact-sized drum kit. It features a 14"x10" bass drum with bass drum lifter, 8"x6" tom tom, 10"x9" floor tom and a 10"x5" snare drum. The Club-JAM Flyer kit delivers a very-well balanced authentic drum sound despite its smaller-sized shells. The Club-JAM Flyer kit's compact size and configuration make it perfect for any small venue or street show. A special drum bag set for the Club-JAM Flyer kit allows for easy transportation (DSS44LJ / sold separately).



COLOR Aqua Blue **AQB**

LJK44H4 14" Bass Drum 4pc basic kit w/ hardware

Drums:

14"x10" bass drum w/ bass drum lifter, 8"x6" tom tom, 10"x9" floor tom, 10"x5" snare drum.

Hardware:

single tom holder, hi-hat stand, drum pedal, snare stand, drum throne.

KIT CONFIGURATION LIST

[14" BD 4pc Shell Kit]

LJK44S 192.000,00

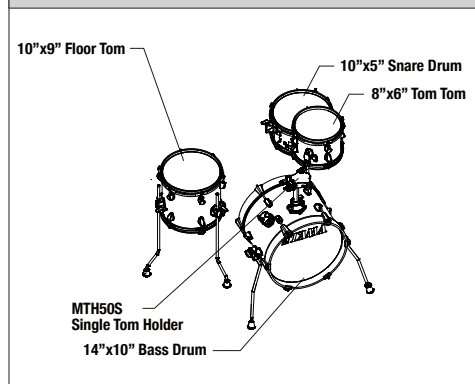

FINISHES (Unicolor Wrap)



Aqua Blue
AQB



Candy Apple Mist
CPM

CLUB-JAM PANCAKE

Unicolor Wrap Finishes

The Club-JAM Pancake kit combines the benefits of a compact & easily portable drum kit with professional quality sound and durability. This is achieved through the lightweight and minimalist design of the Club-JAM series. As the lightest and smallest option in the Club-JAM series, this Club-JAM Pancake kit offers a professional quality sound in any situation. The 3.5" deep tom and floor tom, paired with a 4" deep snare drum and bass drum can be easily packed in just a single bag thanks to the ultrashallow shell. The single-headed toms produce a crisp and warm sound with a strong attack. The double-headed snare drum produces a bright and sharp sound, along with significant low-end from the double-headed bass drum. For every genre, whether you're playing live or in the studio, the Club-JAM Pancake kit delivers a new, unique, and satisfying musical experience.



COLOR Burnt Red Mist **BRM**

LJK48P 18" Bass Drum 4pc basic kit

Drums:
18"x4" bass drum, 10"x3.5" tom tom, 13"x3.5" floor tom, 12"x4" snare drum.

Hardware:
single tom attachment

LJKB18H3 Bass Drum

Drums:
18"x4" bass drum

69,000,00

KIT CONFIGURATION LIST

[18" BD 4pc Shell Kit]

LJK48P 161.000,00

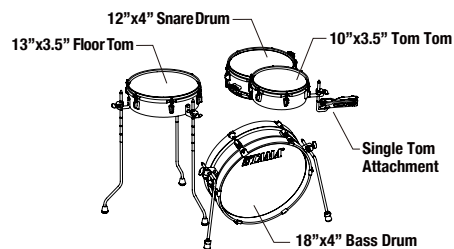

FINISHES (Unicolor Wrap)



Healine Black
HBK



Burnt Red Mist
BRM

COCKTAIL-JAM

Unicolor Wrap Finishes

The Cocktail-JAM Kit™ is a TAMA original in both appearance and sound. It's ideal for hip-hop, jazz, intimate acoustic settings, and tight rehearsal rooms. Completely compact, this kit can easily be set up and played using a throne in spaces much smaller than a typical drum set. Additionally, the Cocktail-JAM Kit and its hardware can be easily packed into just two bags (included with the kit), making it super portable and easy to transport to any gig. Have fun jamming with the Cocktail-JAM Kit!



COLOR Bright Orange Sparkle **BOS**

CJB46C basic kit w/ cymbal attachments

Drums:
16"x6" bass drum, 10"x5" tom tom, 14"x5.5" floor tom, 12"x5" snare drum, Sound Focus Pad, drum bag, hardware bag.

Hardware:
single tom attachments (x2), single pedal, cymbal attachment, hi-hat attachment.

KIT CONFIGURATION LIST

[16" BD 4pc Kit]

CJB46C w/ MCAX5366 Clamp kit 346.000,00

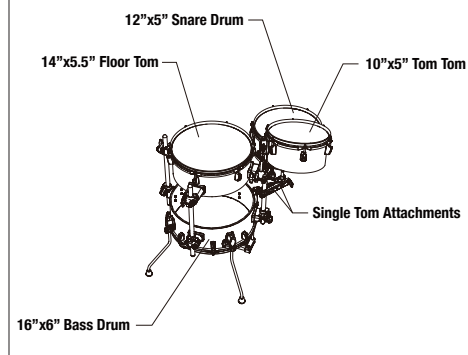

FINISHES (Unicolor Wrap)



Bright Orange Sparkle
BOS



Indigo Sparkle
ISP



Midnight Gold Sparkle
MGD

TRUE TOUCH TRAINING KIT

True Touch Training Kit is a revolutionary practice kit that not only offers the low volume required for practicing at home, but also allows drummers to perform critical technique refinement needed to improve their musical expression. The combination of quiet acoustic volume, realistic acoustic touch and sensitive dynamic expression results in a highly satisfying acoustic drum feeling, something that has not been possible with conventional practice kits until now.



TTK5S Complete Kit

including:
 Solid Kick Bass Pad
 AAD Snare Pad
 8" high tom pad w/ mounting clamp
 8.5" low tom pad w/ mounting clamp
 9" floor tom w/ clamp & boom arm & L-rod
 Tom stand

*Hi-hat stand, cymbal stand, kick pedal and cymbals are not included.

KIT CONFIGURATIONS LIST

[TTK5S 5pc Kit]



*Hi-hat stand, cymbal stand, kick pedal and cymbals are not included.

including:
 Solid Kick Bass Pad
 AAD Snare Pad
 8" high tom pad w/ mounting clamp
 8.5" low tom pad w/ mounting clamp
 9" floor tom w/ clamp & boom arm & L-rod
 Tom stand

231.000,00

[TTK4S 4pc Kit]



*Hi-hat stand, cymbal stand, kick pedal and cymbals are not included.

including:
 Solid Kick Bass Pad
 AAD Snare Pad
 8" high tom pad w/ mounting clamp
 9" floor tom w/ clamp & boom arm & L-rod
 Tom stand

192.000,00

[TTK2S 2pc Kit]



*Hi-hat stand, cymbal stand, kick pedal and cymbals are not included.

including:
 Solid Kick Bass Pad
 AAD Snare Pad

115.000,00

ADD-ON ITEMS

AAD Snare Pad



TTSD10

57.000,00

Acousti-Tone Tom Pad



THT8 8" tom tom

42.000,00

TTLT85 8.5" tom tom
 *Mounting clamp is included.

46.000,00

Acousti-Tone Floor Tom Pad



TFT9 9" floor tom

*Mounting Clamp, boom arm & L-Rod are included.

50.000,00

Solid Kick Bass Pad



TTBD6

65.000,00

Tom Stand



TTKTS

21.200,00

SNARE DRUMS

TAMA has a wide variety of snare drum options to complement our array of drum kits. From our super high end STAR snare drums to the METALWORKS series, which offers quality at a great price, there is a model to fit every drummer's desired sound and budget.

STAR BUBINGA



Color: Natural Indian Laurel -LNTI

TBS1465S

MADE IN JAPAN

Please refer to the STAR Bubinga drum kit page to see available sizes, finishes, and inlay options.

Lug: MSL90SC
Hoop: Die-Cast Hoop (8 hole)
Strainer/Butt: MLS50A/MLS50B
Snare Wire: 14"=MS20RL14C,
13"=MS20RL13C

415.000,00

STAR MAPLE



Color: Gloss Natural Curly Maple -RGCM

TMS1465S

MADE IN JAPAN

Please refer to the STAR Maple drum kit page to see available sizes, finishes, and inlay options.

Lug: MSL90SC
Hoop: Die-Cast Hoop (8 hole)
Strainer/Butt: MLS50A/MLS50B
Snare Wire: 14"=MS20RL14C,
13"=MS20RL13C

415.000,00

STAR WALNUT



Color: Garnet Japanese Sen Burst - AGJB

TWS1465

MADE IN JAPAN

Please refer to the STAR Walnut drum kit page to see available sizes and finishes.

Lug: MSL90SC
Hoop: Die-Cast Hoop (8 hole)
Strainer/Butt: MLS50A/MLS50B
Snare Wire: 14"=MS20RL14C,
13"=MS20RL13C

292.000,00

STAR SOLID MAPLE



Color: Oiled Natural Maple -OMP

TLM146S

MADE IN JAPAN

Shell: 8mm Solid Maple, w/ 8mm Sound Focus Rings

Size: 14"x6"
Lug: MSL90SC
Hoop: Die-Cast Hoop (8 hole)
Strainer/Butt: MLS50A/MLS50B
Snare Wire: MS20RL14C
Color: Oiled Natural Maple (OMP)
[Inlay Option] Outside Inlay, or w/o Inlay

458.000,00

STAR SOLID MAHOGANY



Color: Oiled Natural Mahogany -OMH

TLH146S

MADE IN JAPAN

Shell: 7mm Solid Mahogany w/ 7mm Sound Focus Rings
Size: 14"x6"
Lug: MSL90SC
Hoop: Die-Cast Hoop (8 hole)
Strainer/Butt: MLS50A/MLS50B
Snare Wire: MS20RL14C
Color: Oiled Natural Mahogany (OMH)
[Inlay Option] Outside Inlay, or w/o Inlay

458.000,00

STAR STAVE WALNUT



Color: Oiled Natural Walnut -OWN

TWV146S

MADE IN JAPAN

Shell: 10mm, 16pcs Stave Walnut
Size: 14"x6"
Lug: MSL90SC
Hoop: Die-Cast Hoop (8 hole)
Strainer/Butt: MLS50A/MLS50B
Snare Wire: MS20RL14C
Color: Oiled Natural Walnut (OWN)
[Inlay Option] Outside Inlay, or w/o Inlay

415.000,00

STAR RESERVE SOLID MAPLE



Color: Oiled Natural Maple -OMP

TLM145S

MADE IN JAPAN

Shell: 8mm Solid Maple w/ 8mm Solid Maple Sound Focus Rings
Size: 14"x5"
Lug: MTL150
Hoop: 2.3mm Brass Sound Arc Hoop (8 hole)
Strainer/Butt: MLS50A / MLS50B
Snare Wire: MS20L14C8
Color: Oiled Natural Maple (OMP)

500.000,00

STAR RESERVE BUBINGA/MAPLE



Color: Caramel Olive Ash Burst -OCOB

TMBS158S

MADE IN JAPAN

Shell: 5.5mm, 8ply Bubinga/Maple (1inner ply Cordia+2ply Bubinga+4ply Maple+1outer ply Olive Ash)
Size: 15"x8"
Lug: MSL90TC
Hoop: Brass Mighty Hoop (8 hole)
Strainer/Butt: MLS50A / MLS50B
Snare Wire: MS20SN15S
Color: Caramel Olive Ash Burst (OCOB)

415.000,00

STAR RESERVE WALNUT/BUBINGA



Color: Gloss Claro Walnut -GCW

TBWS1465S

MADE IN JAPAN

Shell: 5.5mm, 4ply Walnut + 2ply Bubinga + 1 outer ply Claro Walnut w/Maple Sound Focus Rings
Size: 14"x6.5"
Lug: MTL160
Hoop: Sound Arc Hoop (10 Hole)
Strainer/Butt: MLS50A / MLS50B
Snare Wire: MS20RL14C
Color: Gloss Claro Walnut (GCW)

415.000,00

STAR RESERVE HAMMERED COPPER



TC1465H

MADE IN JAPAN

Shell: 1.5mm Hammered Copper
Size: 14"x6.5"
Lug: MSL90SC
Hoop: Customized Brass Mighty Hoop (8 Hole)
Strainer/Butt: MLS50A / MLS50B
Snare Wire: MS20RL14C

415.000,00

STAR RESERVE STAVE JATOBA



Color: Oiled Natural Jatoba -OJT

TVJ147S

MADE IN JAPAN

Shell: 10mm, 16pcs Stave Jatoba
Size: 14"x7"
Lug: MTL160
Hoop: Die-Cast Hoop (8 Hole)
Strainer/Butt: MLS50A / MLS50B
Snare Wire: MS20RL14C
Color: Oiled Natural Jatoba (OJT)

458.000,00

STAR RESERVE HAMMERED BRASS



TBRS1455H

MADE IN JAPAN

Shell: 1.5mm Hand Hammered Brass
Size: 14"x5.5"
Lug: MSL90SC
Hoop: Customized Brass Mighty Hoop (8 hole)
Strainer/Butt: MLS50A / MLS50B
Snare Wire: MS20RL14C

415.000,00

STAR RESERVE HAMMERED ALUMINUM



TAS1465H

MADE IN JAPAN

Shell: 3mm Hand Hammered Aluminum
Size: 14"x6.5"
Lug: MSL90SC
Hoop: Brass Sound Arc Hoop (8 hole)
Strainer/Butt: MLS50A / MLS50B
Snare Wire: MS20RL14C

415.000,00

STAR RESERVE STAVE ASH



Color: Oiled Amber Ash -OAA

TVA1465S

MADE IN JAPAN

Shell: 10mm/20pcs Stave Ash Shell
Size: 14"x6.5"
Lug: MSL90SC
Hoop: Sound Arc Hoop (10 hole)
Strainer/Butt: MLS50A/MLS50B
Snare Wire: MS20RL14C
Color: Oiled Amber Ash (OAA)

423.000,00

STAR RESERVE SOLID JAPANESE CEDAR



Color: Burnt Oiled Cedar -BOC

TLJC146

MADE IN JAPAN

Shell: 8mm Solid Japanese Cedar
Size: 14"x6"
Lug: MSL90SC
Hoop: Customized Brass Mighty Hoop (8 hole)
Strainer/Butt: MLS50A/MLS50B
Snare Wire: MS20SN14B
Color: Burnt Oiled Cedar (BOC)

500.000,00

MASTERCRAFT BELL BRASS



BB-156

NEW

MADE IN JAPAN

Shell: 3mm Cast Bell Brass
Size: 14"x6.5"
Lug: Original Superstar Lug (6371N)
Hoop: Die-Cast Hoop (10 hole)
Strainer/Butt: Roller Action (6302N/6303N/6338N)
Snare Wire: 20-strand Carbon Steel Long Snare Wires (6035N)
Inside Muffler: One-Touch Tone Control (6552N)

1.540.000,00

STARPHONIC MAPLE



Color: Satin Mappa Burl - STM

PMM146

MADE IN JAPAN

Shell: 6mm, 6ply Maple + 1 Mappa Burl outer ply
Size: 14"x6"
Lug: Freedom Lug
Hoop: Grooved Hoop
Strainer/Butt: MLS50A/MLS50B
Snare Wire: MS20RL14C
Color: Satin Mappa Burl (STM)

231.000,00

STARPHONIC BUBINGA



Color: Matte Natural Cordia -MNC

PBC146

MADE IN JAPAN

Shell: 7mm, 8ply Bubinga + 1 Cordia outer ply
Size: 14"x6"
Lug: Freedom Lug
Hoop: Grooved Hoop
Strainer/Butt: MLS50A/MLS50B
Snare Wire: MS20RL14C
Color: Matte Natural Cordia (MNC)

231.000,00

STARPHONIC WALNUT



Color: Gloss Black Walnut Burl -GWB

PWB147

MADE IN JAPAN

Shell: 6mm, 6ply American Black Walnut Shell + 1 outer ply Black Walnut Burl
Size: 14"x7"
Lug: Freedom Lug
Hoop: Grooved Hoop
Strainer/Butt: MLS50A/MLS50B
Snare Wire: MS20RL14C
Color: Gloss Black Walnut Burl (GWB)

250.000,00

STARPHONIC BRASS



PBR146

MADE IN JAPAN

Shell: 1.2mm Brass
Size: 14"x6"
Lug: Freedom Lug
Hoop: Grooved Hoop
Strainer/Butt: MLS50A/MLS50B
Snare Wire: MS20RL14C

208.000,00

STARPHONIC BELL BRASS



PBB146

MADE IN JAPAN

Shell: 3mm Bell Brass
Size: 14"x6"
Lug: Freedom Lug
Hoop: Grooved Hoop
Strainer/Butt: MLS50A/MLS50B
Snare Wire: MS20RL14C

916.000,00

STARPHONIC COPPER



PCP147

MADE IN JAPAN

Shell: 1.2mm Copper
Size: 14"x7"
Lug: Freedom Lug
Hoop: Grooved Hoop
Strainer/Butt: MLS50A/MLS50B
Snare Wire: MS20RL14C

269.000,00

STARPHONIC ALUMINUM



PAL146

MADE IN JAPAN

Shell: 1.2mm Seamless Aluminum
Size: 14"x6"
Lug: Freedom Lug
Hoop: Grooved Hoop
Strainer/Butt: MLS50A/MLS50B
Snare Wire: MS20RL14C

184.000,00

STARPHONIC STAINLESS STEEL



PSS146

MADE IN JAPAN

Shell: 1mm Stainless Steel w/ R.S.E.
Size: 14"x6"
Lug: Freedom Lug
Hoop: Grooved Hoop
Strainer/Butt: MLS50A/MLS50B
Snare Wire: MS20RL14C

277.000,00

STARPHONIC STEEL



PST146

MADE IN JAPAN

Shell: 1mm Steel
Size: 14"x6"
Lug: Freedom Lug
Hoop: Grooved Hoop
Strainer/Butt: MLS50A/MLS50B
Snare Wire: MS20RL14C

165.000,00

STARCLASSIC MAPLE EXOTIC FINISH



MES1465U

Please refer to the Starclassic Maple Exotic Finish drum kit page to see available sizes and finishes.

Lug: MSL-SCT
Hoop: Die-Cast Hoop
Strainer/Butt: MLS50A/MLS50B
Snare Wire: 14"=MS20RL14C,
13"=MS20RL13C

246.000,00

Color: Tobacco Sunburst Movingui -VTBV

STARCLASSIC MAPLE LACQUER FINISH



MAS1455

Please refer to the Starclassic Maple Lacquer Finish drum kit page to see available sizes and finishes. Antique Maple (ATM) is also available.

Lug: MSL-SCT
Hoop: Die-Cast Hoop
Strainer/Butt: MLS50A/MLS50B
Snare Wire: 14"=MS20RL14C,
13"=MS20RL13C

238.000,00

Color: Antique Maple -ATM

STARCLASSIC MAPLE DURACOVER WRAP FINISH



MRS136

Please refer to the Starclassic Maple Duracover Wrap Finish drum kit page to see available sizes and finishes.

Lug: MSL-SCT
Hoop: Die-Cast Hoop
Strainer/Butt: MLS50A/MLS50B
Snare Wire: 14"=MS20RL14C,
13"=MS20RL13C

219.000,00

Color: Blue and White Oyster -BWO

STARCLASSIC WALNUT/BIRCH LACQUER FINISH



WBSS65

Please refer to the Starclassic Walnut/Birch Lacquer Finish drum kit page to see available sizes and finishes.

Lug: MSL-SCT
Hoop: Die-Cast Hoop
Strainer/Butt: MLS30A/MLS30B
Snare Wire: 14"=MS20RL14C,
13"=MS20RL13C

181.000,00

Color: Molten Brown Burst -MBR

STARCLASSIC WALNUT/BIRCH DURACOVER WRAP FINISH



WBR65

Please refer to the Starclassic Walnut/Birch Duracover Wrap Finish drum kit page to see available sizes and finishes.

Lug: MSL-SCT
Hoop: Die-Cast Hoop
Strainer/Butt: MLS30A/MLS30B
Snare Wire: 14"=MS20RL14C,
13"=MS20RL13C

181.000,00

Color: Charcoal Onyx -CCO

STARCLASSIC PERFORMER LACQUER FINISH



MBSS65

Please refer to the Starclassic Performer Lacquer Finish drum kit page to see available sizes and finishes.

Lug: MSL-SCT
Hoop: Die-Cast Hoop
Strainer/Butt: MLS30A/MLS30B
Snare Wire: 14"=MS20RL14C,
13"=MS20RL13C

131.000,00

Color: Sky Blue Aurora -SKA

S.L.P. G-BUBINGA



LGB146

NEW

Shell: 10mm, 11ply Bubinga + 1 outer ply Quilted Bubinga
Size: 14"x6"
Lug: MSL-SCTBN
Hoop: Steel Mighty Hoop (10 Hole)
Strainer/Butt: MLS50A/MLS50B
Snare Wire: MS20SN14S
Color: Natural Quilted Bubinga (NQB)

200.000,00

Color: Natural Quilted Bubinga -NQB

S.L.P. G-MAPLE



LGM146

Shell: 11mm, 12ply Maple + 1 outer ply Mappa Burl
Size: 14"x6"
Lug: MSL-SCTBN
Hoop: Steel Mighty Hoop (10 Hole)
Strainer/Butt: MLS50ABN / MLS50BBN
Snare Wire: MS20RL14C
Color: Kona Mappa Burl (KMB)

181.000,00

Color: Kona Mappa Burl -KMB

S.L.P. G-MAPLE



LGM137

Shell: 10mm, 11ply Maple + 1 outer ply Tamo Ash
Size: 13"x7"
Lug: MTL60
Hoop: Die-Cast Hoop (8 hole)
Strainer/Butt: MLS50A/MLS50B
Snare Wire: MS20SN13C
Color: Satin Tamo Ash (STA)

200.000,00

Color: Satin Tamo Ash -STA

S.L.P. G-WALNUT



Color: Matte Black Walnut -MBW

LGW1465

Shell: 9mm, 10ply Walnut
Size: 14"x6.5"
Lug: MTL60
Hoop: Sound Arc Hoop (10 hole)
Strainer/Butt: MLS50A/MLS50B
Snare Wire: MS30R14S
Color: Matte Black Walnut (MBW)

177.000,00

S.L.P. DUO BIRCH



Color: Transparent Mocha -TPM

LBH1410L

Shell: 7mm, 7ply Birch
Size: 14"x10"
Lug: MSL-SCT
Hoop: Sound Arc Hoop (8 hole)
Strainer/Butt: MCS70A/MCS70B
Snare Wire: MS20R14S
Color: Transparent Mocha (TPM)
*MTB25E Brackets are Included.
*MFLSL3P Legs are Included.

154.000,00

S.L.P. FAT SPRUCE



Color: Wild Satin Spruce -WSS

LSP146

Shell: 7mm, 8ply Spruce
Size: 14"x6.5"
Lug: MTL60
Hoop: Die-Cast Hoop (8 hole)
Strainer/Butt: MLS50A/MLS50B
Snare Wire: MS20RL14C
Color: Wild Satin Spruce (WSS), Turquoise (TUQ)

165.000,00

S.L.P. CLASSIC MAPLE



Color: Super Maple -SMP

LMP1455

Shell: 7mm, 8ply Maple
Size: 14"x5.5"
Lug: MTL50
Hoop: Sound Arc Hoop (10 hole)
Strainer/Butt: MLS50A/MLS50B
Snare Wire: MS20RL14C
Color: Super Maple (SMP)

165.000,00

S.L.P. STUDIO MAPLE



Color: Sienna -SEN

LMP1465F

Shell: 5mm, 6ply Maple w/ Sound Focus Rings
Size: 14"x6.5"
Lug: MSL-SCT
Hoop: 100% Maple Wood Hoop (8 hole)
Strainer/Butt: MLS50A/MLS50B
Snare Wire: MS20SN14S
Color: Sienna (SEN)

208.000,00

S.L.P. EXPRESSIVE HAMMERED STEEL



LST146H

NEW

Shell: 1.2mm Hammered Steel
Size: 14"x6"
Lug: MCHL5BN
Hoop: 2.3mm Steel Mighty Hoop (10 hole)
Strainer/Butt: MLS30ABN/MLS30BBN
Snare Wire: MS20SN14S

165.000,00

S.L.P. DYNAMIC BRONZE



LBZ1445

Shell: 1.2mm Bronze in Aged finish
Size: 14"x4.5"
Lug: MSL-SCPBN
Hoop: Die-Cast Hoop (8 hole)
Strainer/Butt: MCS70ABN/MCS70BBN
Snare Wire: MS20SN14C

231.000,00

S.L.P. BLACK BRASS



LBR1465

Shell: 1.5mm Brass
Size: 14"x6.5"
Lug: MSL-SCTBN
Hoop: Steel Mighty Hoop (10 hole)
Strainer/Butt: MLS30ABN/MLS30BBN
Snare Wire: MS42R14S

231.000,00

S.L.P. BIG BLACK STEEL



LST148

Shell: 1mm Steel in Matte Black Finish
Size: 14"x8"
Lug: MSL35BN
Hoop: Steel Mighty Hoop (10 hole)
Strainer/Butt: MLS30ABN/MLS30BBN
Snare Wire: MS20SN14S

107.000,00

S.L.P. CLASSIC DRY ALUMINUM



LAL1455

Shell: 1.2mm Seamless Aluminum
Size: 14"x5.5"
Lug: MCHL5S
Hoop: Steel Mighty Hoop (8 hole)
Strainer/Butt: MLS30A/MLS30B
Snare Wire: MS20R14C

154.000,00

METALWORKS



BST1055MBK

Shell: 1mm Steel
Size: 10"x5.5"
Lug: MSL60SBK
Hoop: Triple Flanged Hoop (6 hole)
Strainer/Butt: MUS65ABK/MUS60BBK
Snare Wire: MS16R10S
*Tom bracket is equipped.

54.000,00

METALWORKS



BST134BK

Shell: 1mm Steel
Size: 13"x4"
Lug: MSL-SCPBK
Hoop: Triple Flanged Hoop (6 hole)
Strainer/Butt: MCS70ABK/MCS70BBK
Snare Wire: MS20R13S

55.000,00

METALWORKS



BST1455BK
 Shell: 1mm Steel
 Size: 14"x5.5"
 Lug: MSL60SBK
 Hoop: Triple Flanged Hoop (8 hole)
 Strainer/Butt: MUS65ABK/MUS60BBK
 Snare Wire: MS20R14S

57.000,00

METALWORKS



BST1465BK
 Shell: 1mm Steel
 Size: 14"x6.5"
 Lug: MSL60SBK
 Hoop: Triple Flanged Hoop (8 hole)
 Strainer/Butt: MUS65ABK/MUS60BBK
 Snare Wire: MS20R14S

61.000,00

METALWORKS EFFECT MINI-TYMP SNARE DRUMS



BST63MBK
 Shell: 1mm Steel
 Size: 6"x3"
 Lug: MSL80TBK
 Hoop: Triple Flanged Hoop (4 hole)
 Snare Wire: Mod Tone System w/ Snare Wire
 *Tom bracket is equipped.
 *MC69 single tom attachment is included.

59.000,00

METALWORKS EFFECT MINI-TYMP SNARE DRUMS



BST83MBK
 Shell: 1mm Steel
 Size: 8"x3"
 Lug: MSL80TBK
 Hoop: Triple Flanged Hoop (4 hole)
 Snare Wire: Mod Tone System w/ Snare Wire
 *Tom bracket is equipped.
 *MC69 single tom attachment is included.

61.000,00

METALWORKS EFFECT MINI-TYMP SNARE DRUMS



BST103MBK
 Shell: 1mm Steel
 Size: 10"x3"
 Lug: MSL80TBK
 Hoop: Triple Flanged Hoop (6 hole)
 Snare Wire: Mod Tone System w/ Snare Wire
 *Tom bracket is equipped.
 *MC69 single tom attachment is included.

65.000,00

METALWORKS EFFECT MINI-TYMP SNARE DRUMS



BST143MBK
 Shell: 1mm Steel
 Size: 14"x3"
 Lug: MSL80TBK
 Hoop: Triple Flanged Hoop (6 hole)
 Snare Wire: Mod Tone System w/ Snare Wire
 *Tom bracket is equipped.
 *MC69 single tom attachment is included.

69.000,00

WOODWORKS



Color: Black Oak Wrap (BOW)

WP1455BK
 Shell: 8mm, 8ply Poplar
 Size: 14"x5.5"
 Lug: MSL60SBK
 Hoop: Triple Flanged Hoop (8 hole)
 Strainer/Butt: MUS65ABK/MUS60BBK
 Snare Wire: MS20R14S
 Color: Natural ZebraWood Wrap (NZW), Black Oak Wrap (BOW)

55.000,00

WOODWORKS



Color: Natural ZebraWood Wrap (NZW)

WP1465BK
 Shell: 8mm, 8ply Poplar
 Size: 14"x6.5"
 Lug: MSL60SBK
 Hoop: Triple Flanged Hoop (8 hole)
 Strainer/Butt: MUS65ABK/MUS60BBK
 Snare Wire: MS20R14S
 Color: Natural ZebraWood Wrap (NZW), Black Oak Wrap (BOW)

55.000,00

WOODWORKS



Color: Black Oak Wrap (BOW)

WP148BK
 Shell: 8mm, 8ply Poplar
 Size: 14"x8"
 Lug: MSL60SBK
 Hoop: Triple Flanged Hoop (8 hole)
 Strainer/Butt: MUS65ABK/MUS60BBK
 Snare Wire: MS20R14S
 Color: Natural ZebraWood Wrap (NZW), Black Oak Wrap (BOW)

59.000,00

SIGNATURE PALETTE -CHARLIE BENANTE



MADE IN JAPAN

CB1465
 Shell: 1.2mm Stainless Steel
 Size: 14"x6.5"
 Lug: MSL35BN
 Hoop: Die-Cast Hoop (10 hole)
 Strainer/Butt: MSL50ABN/MLS50BN
 Snare Wire: MS20SN14S

231.000,00

SIGNATURE PALETTE -STEWART COPELAND



MADE IN JAPAN

SC145
 Shell: 1.5mm Brass
 Size: 14"x5"
 Lug: MSL35
 Hoop: Die-Cast Hoop (10 hole, Batter side)/Steel Mighty Hoop (10 hole, Snare side)
 Strainer/Butt: MSL50A/MLS50B
 Snare Wire: MS20SN14S

231.000,00

SIGNATURE PALETTE -PETER ERSKINE



MADE IN JAPAN

PE106M
 Shell: 10mm, 12pcs Stave Ash
 Size: 10"x6"
 Lug: MSL90SC
 Hoop: Die-Cast Hoop (6 Hole)
 Strainer/Butt: MSL50A / MLS50B
 Snare Wire: MS20SN10S
 Super Resonant Mounting System Equipped

458.000,00

SIGNATURE PALETTE -PETER ERSKINE



PE1445

MADE IN JAPAN

Shell: 6mm, 4ply Spruce + 2 inner ply Maple w/ Sound Focus Ring only for batter side (Same configuration : 6mm, 4ply Spruce + 2 inner ply Maple)
Size: 14"x4.5"
Lug: MTL145
Hoop: 2.3mm Sound Arc Hoop (8 Hole)
Strainer/Butt: MLS50A / MLS50B
Snare Wire: MS20RL14C

204.000,00

SIGNATURE PALETTE -MIKE PORTNOY



MP125ST

MADE IN JAPAN

Shell: 1mm Steel (Hammered Matte Black)
Size: 12"x5"
Lug: MSL-SCT
Hoop: Die-Cast Hoop (6 hole)
Strainer/Butt: MCS100A/MCS70B
Snare Wire: MS20SN12S

200.000,00

SIGNATURE PALETTE -MIKE PORTNOY



MP1455ST

MADE IN JAPAN

Shell: 1mm Steel (Hammered Matte Black)
Size: 14"x5.5"
Lug: MSL-SCT
Hoop: Die-Cast Hoop (8 hole)
Strainer/Butt: MCS100A/MCS70B
Snare Wire: MS20SN14S

223.000,00

SIGNATURE PALETTE -MIKE PORTNOY



MP1455BU

MADE IN JAPAN

Shell: 8mm, 9ply Bubinga
Size: 14"x5.5"
Lug: MSL-SCT
Hoop: Die-Cast Hoop (8 hole)
Strainer/Butt: MCS100A/MCS70B
Snare Wire: MS20SN14S

277.000,00

SIGNATURE PALETTE -JOHN TEMPESTA



JT147

MADE IN JAPAN

Shell: 2mm Brass
Size: 14"x7"
Lug: MSL-SCTBN
Hoop: Die-Cast Hoop (10 hole)
Strainer/Butt: MLS50ABN/MLS50BBN
Snare Wire: MS42R14S

335.000,00

SIGNATURE PALETTE -LARS ULRICH



LU1465N

MADE IN JAPAN

Shell: 3mm Diamond Plate Steel
Size: 14"x6.5"
Lug: MSL35
Hoop: Die-Cast Hoop (10 hole)
Strainer/Butt: MLS50A/MLS50B
Snare Wire: MS20SN14S

335.000,00

DRUM PEDALS

Our Iron Cobra pedals have long been praised for being smooth, reliable, and independently adjustable. Iron Cobra pedals are offered in the high end 900 series as well as the standard 600 and 200 models. Speed Cobra 910 and 310 drum pedals feature a longer footboard for a lighter, quicker feel. Our drum pedal range is designed to fit the needs of every drummer.

DYNA-SYNC SINGLE PEDAL



HPDS1

- Optimized Transmission Design
- Dual Linkage
- Slidable Cam
- Footboard Angle Adjustment
- Dyna Beater
- Swivel Spring Tight
- Speedo-Ring
- Oiles Bearing Hinge
- Para-Clamp II Pro
- Sync-Coil
- Hinge Guard Block
- Hardshell Carrying Case

142.000,00

DYNA-SYNC TWIN PEDAL



HPDS1TW

- Optimized Transmission Design
- Dual Linkage
- Slidable Cam
- Footboard Angle Adjustment
- Dyna Beater
- Swivel Spring Tight
- Speedo-Ring
- Oiles Bearing Hinge
- Para-Clamp II Pro
- Sync-Coil
- Hinge Guard Block
- Hardshell Carrying Case

308.000,00

DYNA-SYNC TWIN PEDAL



HPDS1TWL

- Left-Footed
- Optimized Transmission Design
- Dual Linkage
- Slidable Cam
- Footboard Angle Adjustment
- Dyna Beater
- Swivel Spring Tight
- Speedo-Ring
- Oiles Bearing Hinge
- Para-Clamp II Pro
- Sync-Coil
- Hinge Guard Block
- Hardshell Carrying Case

308.000,00

SPEED COBRA 910 SINGLE PEDAL



HP910LN

- Long Footboard
- Recessed Setting
- Rolling Glide LiteSprocket Cam
- Accu-Strike Cobra Beater
- Swivel Spring Tight
- Super Stabilizer Design
- Para-Clamp II Pro
- Cobra Coil
- Hinge Guard Block
- Hardshell Carrying Case

107.000,00

SPEED COBRA 910 TWIN PEDAL



HP910LWN

- Long Footboard
- Recessed Setting
- Rolling Glide LiteSprocket Cam
- Accu-Strike Cobra Beater
- Swivel Spring Tight
- Super Stabilizer Design
- Para-Clamp II Pro
- Cobra Coil
- Hinge Guard Block
- Hardshell Carrying Case

231.000,00

SPEED COBRA 910 TWIN PEDAL



HP910LWLN

- Left-Footed
- Long Footboard
- Recessed Setting
- Rolling Glide LiteSprocket Cam
- Accu-Strike Cobra Beater
- Swivel Spring Tight
- Super Stabilizer Design
- Para-Clamp II Pro
- Cobra Coil
- Hinge Guard Block
- Hardshell Carrying Case

231.000,00

IRON COBRA 900 SINGLE PEDAL -POWER GLIDE-



HP900PN

- Power Glide LiteSprocket Cam
- Power-Strike Cobra Beater
- Swivel Spring Tight
- Super Stabilizer Design
- Para-Clamp II Pro
- Cobra Coil
- Hinge Guard Block
- Hardshell Carrying Case

107.000,00

IRON COBRA 900 TWIN PEDAL -POWER GLIDE-



HP900PWN

- Power Glide LiteSprocket Cam
- Power-Strike Cobra Beater
- Swivel Spring Tight
- Super Stabilizer Design
- Para-Clamp II Pro
- Cobra Coil
- Hinge Guard Block
- Hardshell Carrying Case

231.000,00

IRON COBRA 900 TWIN PEDAL -POWER GLIDE-



HP900PWLN

- Left-Footed
- Power Glide LiteSprocket Cam
- Power-Strike Cobra Beater
- Swivel Spring Tight
- Super Stabilizer Design
- Para-Clamp II Pro
- Cobra Coil
- Hinge Guard Block
- Hardshell Carrying Case

231.000,00

IRON COBRA 900 SINGLE PEDAL -ROLLING GLIDE-



HP900RN

- Rolling Glide LiteSprocket Cam
- Power-Strike Cobra Beater
- Swivel Spring Tight
- Super Stabilizer Design
- Para-Clamp II Pro
- Cobra Coil
- Hinge Guard Block
- Hardshell Carrying Case

107.000,00

IRON COBRA 900 TWIN PEDAL -ROLLING GLIDE-



HP900RWN

- Rolling Glide LiteSprocket Cam
- Power-Strike Cobra Beater
- Swivel Spring Tight
- Super Stabilizer Design
- Para-Clamp II Pro
- Cobra Coil
- Hinge Guard Block
- Hardshell Carrying Case

231.000,00

IRON COBRA 600 SINGLE PEDAL -DUO GLIDE-



HP600D

- Duo Glide
- Double Chain Drive
- Speedo-Ring
- Para-Clamp
- Spring Tension Adjustment
- Beater Angle Adjustment
- Dual Sided Beater

57.000,00

IRON COBRA 600 TWIN PEDAL -DUO GLIDE-



HP600DTW

- Duo Glide
- Double Chain Drive
- Speedo-Ring
- Para-Clamp
- Spring Tension Adjustment
- Beater Angle Adjustment
- Dual Sided Beater

146.000,00

SPEED COBRA 310 SINGLE PEDAL



HP310L

- Long Footboard
- Recessed Setting
- Rolling Glide LiteSprocket
- Double Chain Drive
- Spring Tension Adjustment
- Beater Angle Adjustment
- Dual Sided Beater

50.000,00

SPEED COBRA 310 TWIN PEDAL



HP310LW

- Long Footboard
- Recessed Setting
- Rolling Glide LiteSprocket
- Double Chain Drive
- Spring Tension Adjustment
- Beater Angle Adjustment
- Dual Sided Beater

134.000,00

IRON COBRA 200 SINGLE PEDAL



HP200P

- Power Glide
- Spring Tension Adjustment
- Beater Angle Adjustment
- Dual Sided Beater

38.100,00

IRON COBRA 200 TWIN PEDAL



HP200PTW

- Power Glide
- Spring Tension Adjustment
- Beater Angle Adjustment
- Dual Sided Beater

107.000,00

IRON COBRA 200 TWIN PEDAL



HP200PTWL

- Left-Footed
- Power Glide
- Spring Tension Adjustment
- Beater Angle Adjustment
- Dual Sided Beater

107.000,00

STANDARD SINGLE PEDAL



HP30

- Power Glide
- Spring Tension Adjustment
- Beater Angle Adjustment
- Dual Sided Beater

27.700,00

STANDARD TWIN PEDAL



HP30TW

- Power Glide
- Spring Tension Adjustment
- Beater Angle Adjustment
- Dual Sided Beater

61.000,00

THE CLASSIC PEDAL



HP50

- Center Strike Height Adjust
- Easy Access Spring Adjustment
- The Classic Beater
- Smooth Surface Footboard
- Individual Adjustment of Beater & Footboard Angle
- Easy-Tight Hoop Clamp
- Compact Folding Design

50.000,00

TWIN PEDAL ATTACHMENT



TPA90

Specially designed attachment to connect Speed Cobra 910 and Iron Cobra 900 series pedals with Speed Cobra 910 and Iron Cobra 900 series Hi-hat stands.

5.740,00

HI-HAT STANDS

In addition to bass drum pedals, we offer various hi-hat stands including our high end Dyna-Sync, Iron Cobra & Speed Cobra models as well as our standard Stage Master models.

DYNA-SYNC HI-HAT STAND



HHDS1

- Direct Drive Action
- Spring Damper for Reducing Noise
- Quick-Set Hi-Hat Clutch
- 6-way Tension Adjustment
- Footboard Angle Adjustment
- Bigger Rubber Feet w/Duo-Spike
- Weight: 5.2kg (11.7lbs)
- Height Adjustment Range: 745mm-960mm (29 3/8" - 37 3/4") (Standard Rod) / 745mm-810mm (29 3/8" - 31 7/8") (Short Rod)

169.000,00

SPEED COBRA 910 HI-HAT STAND - LEVER GLIDE



HH915D

- Spring Seat
- Quick-Set Hi-Hat Clutch
- 6-way Tension Adjustment
- Bigger Rubber Feet w/Duo-Spike
- Weight: 5.2kg (11.7lbs)
- Height Adjustment Range: 745mm-960mm (29 3/8" - 37 3/4") (Standard Rod) / 745mm-810mm (29 3/8" - 31 7/8") (Short Rod)

146.000,00

IRON COBRA 900 HI-HAT STAND -LEVER GLIDE



HH905D

- Spring Seat
- Quick-Set Hi-Hat Clutch
- 6-way Tension Adjustment
- Bigger Rubber Feet w/Duo-Spike
- Weight: 5.2kg (11.7lbs)
- Height Adjustment Range: 745mm-960mm (29 3/8" - 37 3/4") (Standard Rod) / 745mm-810mm (29 3/8" - 31 7/8") (Short Rod)

146.000,00

IRON COBRA 900 HI-HAT STAND -VELO GLIDE



HH805D

- Spring Seat
- Quick-Set Hi-Hat Clutch
- 6-way Tension Adjustment
- Bigger Rubber Feet w/Duo-Spike
- Weight: 5.2kg (11.7lbs)
- Height Adjustment Range: 745mm-960mm (29 3/8" - 37 3/4") (Standard Rod) / 745mm-810mm (29 3/8" - 31 7/8") (Short Rod)

138.000,00

IRON COBRA 900 REMOTE HI-HAT STAND



HH905RH

- JAGWIRE™ Triple-Layered Ultra-Smooth Cable
- Quick-Set Hi-Hat Clutch
- Lever Glide
- 6-way Tension Adjustment
- MC66 Universal Clamp
- Ratchet Arm (Φ12mm, Arm Length: 200mm)
- Dual Leg
- Cable Holders (x 6)
- Carrying Bag
- Weight: 8.1kg (17lbs)

223.000,00

IRON COBRA 600 HI-HAT STAND



HH605

- Spring Seat
- Swing Lock Clutch
- 6-way Tension Adjustment
- Swivel Foot
- Direct Pull Action
- Footboard Angle Adjustment
- Weight: 4.3kg (9.7lbs)
- Height Adjustment Range: 710mm-930mm (28" - 36 5/8")

77.000,00

SPEED COBRA 310 HI-HAT STAND



HH315D

- Dual Leg
- 28.6mm Diameter Base Section Tubing
- Security Clutch
- 6-way Tension Adjustment
- Swivel Foot
- Direct Pull Action
- Weight: 3.9kg (8.9lbs)
- Height Adjustment Range: 710mm-930mm (28" - 36 5/8")

63.000,00

IRON COBRA 200 HI-HAT STAND



HH205

- Double Braced Legs
- 5-way Tension Adjustment
- Swivel Foot
- Direct Pull Action
- Non-Loosening Tension Rod
- Toe Guard
- Security Clutch
- Weight: 3.8kg (8.6lbs)
- Height Adjustment Range: 670mm-930mm (26 3/8" - 36 5/8")

54.000,00

IRON COBRA 200 HI-HAT STAND



HH205S

- Single Braced Legs
- 5-way Tension Adjustment
- Swivel Foot
- Direct Pull Action
- Non-Loosening Tension Rod
- Toe Guard
- Security Clutch
- Weight: 3.1kg (6.8lbs)
- Height Adjustment Range: 670mm-930mm (26 3/8" - 36 5/8")

50.000,00

STAGE MASTER HI-HAT STAND



HH45WN

- Double Braced Legs
- Swivel Foot
- Direct Pull Action
- Non-Loosening Tension Rod
- Toe Guard
- Security Clutch
- Weight: 3.4kg (7.6lbs)
- Height Adjustment Range: 670mm-930mm (26 3/8" - 36 5/8")

40.000,00

THE CLASSIC HI-HAT STAND



HH55F

- Single Braced Flat Base Tripod Legs
- Individual Adjustment of Spring Tension & Footboard Angle
- Knurling on Base Pipe
- Memory Lock
- Weight: 2.3kg (5.1 lbs)
- Height Adjustment Range: 650mm-950mm (24 5/8" - 37 3/8")
- Storage size: 500mm (19 11/16") (upper section) / 600mm (23 5/8") (lower section)

46.000,00

DRUM THRONES

Being comfortable on your drum set is one of the most important aspects of drumming, making the drum throne a vital yet often overlooked piece of equipment. Our ergonomic 1st Chair Drum Thrones have many original TAMA features to guarantee comfort, stability, and quick, easy setup.

1ST CHAIR ROUND RIDER XL DRUM THRONE -CLOTH TOP



HT850BC

Round Rider XL "Cloth Top" Seat
 -15" Diameter, 130mm (5 1/8") Thick Round Seat
 -HYDRAULIX
 -Seat Lock
 -Oversized Rubber Feet
 -Foot Life
 -Weight: 6.0kg (13.3lbs)
 -Height Adjustment Range: 515mm - 695mm (21 1/4" - 27 3/8")

115.000,00

1ST CHAIR ROUND RIDER XL DRUM THRONE



HT830R

Round Rider XL Seat
 -15" Diameter, 130mm (5 1/8") Thick Round Seat
 -1st Chair Height Adjustment
 -Seat Lock
 -Glide-Tite Grip Joint
 -Rocklok
 -Oversized Rubber Feet
 -Foot Life
 -Weight: 6.0kg (13.3lbs)
 -Height Adjustment Range: 515mm - 670mm (21 1/4" - 26 3/8")

104.000,00

1ST CHAIR ROUND RIDER XL DRUM THRONE



HT830B

Round Rider XL Seat
 -15" Diameter, 130mm (5 1/8") Thick Round Seat
 -1st Chair Height Adjustment
 -Seat Lock
 -Glide-Tite Grip Joint
 -Rocklok
 -Oversized Rubber Feet
 -Foot Life
 -Weight: 6.0kg (13.3lbs)
 -Height Adjustment Range: 515mm - 670mm (21 1/4" - 26 3/8")

104.000,00

1ST CHAIR ERGO-RIDER DRUM THRONE -CLOTH TOP



HT750BC

Ergo-Rider "Cloth Top" Seat
 -HYDRAULIX
 -Seat Lock
 -Oversized Rubber Feet
 -Foot Life
 -Weight: 6.1kg (13.7lbs)
 -Height Adjustment Range: 505mm - 685mm (19 7/8" - 27")

115.000,00

1ST CHAIR ERGO-RIDER DRUM THRONE



HT730B

Ergo-Rider Seat
 -1st Chair Height Adjustment
 -Seat Lock
 -Glide-Tite Grip Joint
 -Rocklok
 -Oversized Rubber Feet
 -Foot Life
 -Weight: 6.1kg (13.7lbs)
 -Height Adjustment Range: 505mm - 660mm (19 7/8" - 26")

104.000,00

1ST CHAIR ERGO-RIDER DRUM THRONE -QUARTET



HT741B

Ergo-Rider Seat
 -1st Chair Height Adjustment
 -Seat Lock
 -Backrest
 -Glide-Tite Grip Joint
 -Rocklok
 -Oversized Rubber Feet
 -Foot Life
 -Weight: 9.4kg (20.1lbs)
 -Height Adjustment Range: 515mm - 665mm (20 1/4" - 26 3/6")

154.000,00

1ST CHAIR GLIDE RIDER DRUM THRONE -CLOTH TOP



HT550BCN

Glide Rider "Cloth Top" Seat
 -HYDRAULIX
 -Seat Lock
 -Glide-Tite Grip Joint
 -Oversized Rubber Feet
 -Foot Life
 -Weight: 5.9kg (13lbs)
 -Height Adjustment Range: 470mm - 650mm (18 1/2" - 24 5/8")

115.000,00

1ST CHAIR GLIDE RIDER DRUM THRONE -CLOTH TOP



HT530BCN

Glide Rider "Cloth Top" Seat
 -1st Chair Height Adjustment
 -Seat Lock
 -Glide-Tite Grip Joint
 -Rocklok
 -Oversized Rubber Feet
 -Foot Life
 -Weight: 5.9kg (13lbs)
 -Height Adjustment Range: 470mm - 675mm (18 1/2" - 26 1/2")

104.000,00

1ST CHAIR WIDE RIDER DRUM THRONE -CLOTH TOP



HT530BC

Wide Rider "Cloth Top" Seat
-1st Chair Height Adjustment
-Seat Lock
-Glide-Tite Grip Joint
-Rocklok
-Oversized Rubber Feet
-Foot Life
-Weight: 6.0kg (13.3lbs)
-Height Adjustment Range: 485mm - 640mm (19" - 25 3/16")

104.000,00

1ST CHAIR WIDE RIDER DRUM THRONE



HT530B

Wide Rider Seat
-1st Chair Height Adjustment
-Seat Lock
-Glide-Tite Grip Joint
-Rocklok
-Oversized Rubber Feet
-Foot Life
-Weight: 6.0kg (13.3lbs)
-Height Adjustment Range: 485mm - 640mm (19" - 25 3/16")

104.000,00

1ST CHAIR ROUND RIDER DRUM THRONE -CLOTH TOP



HT430BC

Round Rider "Cloth Top" Seat
-14" Diameter, 120mm (4 3/4") Thick Round Seat
-1st Chair Height Adjustment
-Seat Link
-Rocklok
-Foot Life
-Weight: 5.3kg (11.1lbs)
-Height Adjustment Range: 485mm - 655mm (19" - 25 3/4")

73.000,00

1ST CHAIR ROUND RIDER DRUM THRONE



HT430B

Round Rider Seat
-14" Diameter, 120mm (4 3/4") Thick Round Seat
-1st Chair Height Adjustment
-Seat Link
-Rocklok
-Foot Life
-Weight: 5.3kg (11.1lbs)
-Height Adjustment Range: 485mm - 655mm (19" - 25 3/4")

73.000,00

1ST CHAIR SADDLE-TYPE DRUM THRONE



HT250

Saddle-Type Seat
-1st Chair Height Adjustment
-Glide-Tite Grip Joint
-Rocklok
-Foot Life
-Weight: 4.05kg (8.9lbs)
-Height Adjustment Range: 425mm - 625mm (16 3/4" - 24 1/2")

59.000,00

1ST CHAIR ROUNDED TYPE DRUM THRONE



HT230

Rounded Seat
-1st Chair Height Adjustment
-Glide-Tite Grip Joint
-Rocklok
-Foot Life
-Weight: 4.0kg (8.8lbs)
-Height Adjustment Range: 460mm - 660mm (18" - 26")

50.000,00

1ST CHAIR LOW PROFILE ROUNDED TYPE DRUM THRONE



HT230LOW

Rounded Seat
-1st Chair Height Adjustment
-Glide-Tite Grip Joint
-Rocklok
-Foot Life
-Weight: 3.6kg (8lbs)
-Height Adjustment Range: 374mm - 519mm (15" - 20 1/2")

50.000,00

STANDARD DRUM THRONE



HT130

-13" Diameter, 90mm (3 1/2") Thick Round Seat
-Double Braced Legs
-Weight: 3.4kg (7.7lbs)
-Height Adjustment Range: 445mm - 620mm (17 1/2" - 24 7/16")

34.300,00

SNARE STANDS

Our STAR snare stand has several unique features which provide the ultimate solution for a flexible and stable snare drum setup. Our Roadpro stands now have greater stability, in addition to Quick-Set universal tilters.

STAR HARDWARE SNARE STAND



HS100W

For 12" to 15" Diameter Snare Drums
 -28.6mm Diameter Base Section Tubing
 -Cradle-Hold Snare Basket
 -Glide-Tite Grip Joint
 -True-Sound Insulation Mute
 -Oversized Rubber Feet with Retractable Spike
 -Weight: 3.9kg (8.9lbs)
 -Height Adjustment Range: 400mm - 600mm (15 3/4" - 23 5/8")

84.000,00

ROADPRO SNARE STAND



HS800W

For 12" to 15" Diameter Snare Drums
 -28.6mm Diameter Base Section Tubing
 -Omni-Ball Tilter
 -Swiveling Basket
 -Glide-Tite Grip Joint
 -Double Braced Legs
 -Weight: 3.4kg (7.7lbs)
 -Height Adjustment Range: 495mm - 665mm (19 1/2" - 26 3/8")

59.000,00

ROADPRO SNARE STAND



HS80W

For 12" to 15" Diameter Snare Drums
 -28.6mm Diameter Base Section Tubing
 -Quick-Set Tilter
 -Swiveling Basket
 -Glide-Tite Grip Joint
 -Double Braced Legs
 -Weight: 3.2kg (7lbs)
 -Height Adjustment Range: 495mm - 640mm (19 1/2" - 25 3/16")

42.000,00

ROADPRO SNARE STAND



HS80PW

For 10" to 12" Diameter Snare Drums
 -28.6mm Diameter Base Section Tubing
 -Quick-Set Tilter
 -Swiveling Basket
 -Glide-Tite Grip Joint
 -Double Braced Legs
 -Weight: 3.2kg (7lbs)
 -Height Adjustment Range: 465mm - 610mm (18 5/16" - 24")

42.000,00

ROADPRO SNARE STAND



HS80LOW

For 12" to 15" Diameter Snare Drums
 -28.6mm Diameter Base Section Tubing
 -Low Position Setting Basket
 -Quick-Set Tilter
 -Glide-Tite Grip Joint
 -Double Braced Legs
 -Weight: 3.3kg (7.4lbs)
 -Height Adjustment Range: 385mm - 530mm (15 3/16" - 20 7/8")

55.000,00

60 SERIES SNARE STAND



HS60W

For 12" to 15" Diameter Snare Drums
 -25.4mm Diameter Base Section Tubing
 -Quick-Set Tilter
 -Swiveling Basket
 -Double Braced Legs
 -Weight: 2.6kg (5.1lbs)
 -Height Adjustment Range: 470mm - 600mm (18 1/2" - 23 5/8")

38.100,00

STAGE MASTER SNARE STAND



HS40WN

For 12" to 15" Diameter Snare Drums
 -25.4mm Diameter Base Section Tubing
 -Universal Gearless Tilter
 -Swiveling Basket
 -Double Braced Legs
 -Weight: 2.6kg (5.11lbs)
 -Height Adjustment Range: 470mm - 630mm (18 1/2" - 24 13/16")

30.400,00

STAGE MASTER SNARE STAND



HS40PWN

For 10" to 12" Diameter Snare Drums
 -25.4mm Diameter Base Section Tubing
 -Universal Gearless Tilter
 -Swiveling Basket
 -Double Braced Legs
 -Weight: 2.6kg (5.11lbs)
 -Height Adjustment Range: 470mm - 630mm (18 1/2" - 24 13/16")

30.400,00

STAGE MASTER SNARE STAND



HS40SN

For 12" to 15" Diameter Snare Drums
 -25.4mm Diameter Base Section Tubing
 -Universal Gearless Tilter
 -Swiveling Basket
 -Single Braced Legs
 -Weight: 2.5kg (5.8lbs)
 -Height Adjustment Range: 470mm - 630mm (18 1/2" - 24 13/16")

30.400,00

STAGE MASTER SNARE STAND



HS40LOWN

For 12" to 15" Diameter Snare Drums
 -25.4mm Diameter Base Section Tubing
 -Low Position Setting Basket
 -Universal Gearless Tilter
 -Double Braced Legs
 -Weight: 2.7kg (5.15lbs)
 -Height Adjustment Range: 370mm - 530mm (14 9/16" - 20 7/8")

30.400,00

THE CLASSIC SNARE STAND



HS50S

For 12" to 15" Diameter Snare Drums
 -19.1mm Diameter Base Section Tubing
 -Single Braced Tripod Legs
 -Classic Style Basket
 -Double Braced Arms
 -Gearless Tilter
 -Memory Lock
 -Weight: 1.7kg (3.11lbs)
 -Height Adjustment Range: 390mm-580mm (15 3/8" - 22 7/8")
 -Storage size: 600mm (23 5/8")

32.300,00

CYMBAL STANDS

The TAMA STAR Hardware cymbal stand is incredibly flexible with several groundbreaking adjustment features. The Roadpro cymbal stands benefit from greater stability, and include the same great Quick-Set Tilter and Quick-Set Cymbal Mates.

STAR HARDWARE CYMBAL STAND



HC103BW

-28.6mm Diameter Base Section Tubing
 -Orbital Quick-Tite Cymbal/Boom Tilter
 -Glide-Tite Grip Joint
 -True-Sound Insulation Mute
 -Ring-True Cymbal Felt
 -Boom Arm Length: 450mm (17 3/4")
 -Weight: 6.1kg (13.7lbs)
 -Height Adjustment Range: 890mm - 2,090mm (35" - 82 1/4")

105.000,00

ROADPRO CYMBAL STAND



HC84BW

-28.6mm Diameter Base Section Tubing
 -Quick-Set Tilter
 -Quick-Set Cymbal Mate
 -Boom/Straight Convertible Tilter
 -Glide-Tite Grip Joint
 -Detachable Counter Weight
 -Boom Arm Length : 688mm (27 3/32")
 -Weight : 6.2kg (13.10lbs)
 -Height Adjustment Range: 820mm - 2,200mm (32 1/4" - 86 5/8")

61.000,00

ROADPRO CYMBAL STAND



HC83BW

-28.6mm Diameter Base Section Tubing
 -Quick-Set Tilter
 -Quick-Set Cymbal Mate
 -Boom/Straight Convertible Tilter
 -Glide-Tite Grip Joint
 -Double Braced Legs
 -Boom Arm Length: 450mm (17 3/4")
 -Weight: 5.0kg (11lbs)
 -Height Adjustment Range: 820mm - 2,100mm (32 1/4" - 82 5/8")

46.000,00

ROADPRO CYMBAL STAND



HC82W

-28.6mm Diameter Base Section Tubing
 -Quick-Set Tilter
 -Quick-Set Cymbal Mate
 -Glide-Tite Grip Joint
 -Double Braced Legs
 -Weight: 4.2kg (9.4lbs)
 -Height Adjustment Range: 740mm - 1,610mm (29 1/8" - 72 7/8")

40.000,00

ROADPRO LIGHT CYMBAL STAND



HC83BLS

- 25.4mm Diameter Base Section Tubing
- Quick-Set Tilter
- Quick-Set Cymbal Mate
- Boom/Straight Convertible Tilter
- Glide-Tite Grip Joint
- Single Braced Legs
- Boom Arm Length: 400mm (15 3/4")
- Weight: 3.8kg (8.6lbs)
- Height Adjustment Range: 790mm - 1,850mm (31 1/8" - 72 7/8")

46.000,00

ROADPRO LIGHT CYMBAL STAND



HC82LS

- 25.4mm Diameter Base Section Tubing
- Quick-Set Tilter
- Quick-Set Cymbal Mate
- Glide-Tite Grip Joint
- Single Braced Legs
- Weight: 3.1kg (6.13lbs)
- Height Adjustment Range: 710mm - 1,410mm (28" - 55 1/2")

40.000,00

60 SERIES CYMBAL STAND



HC63BW

- 25.4mm Diameter Base Section Tubing
- Quick-Set Tilter
- Boom/Straight Convertible Tilter
- Double Braced Legs
- Boom Arm Length: 400mm (15 3/4")
- Weight: 3.9kg (8.9lbs)
- Height Adjustment Range: 850mm - 2,010mm (33 1/2" - 79 1/8")

42.000,00

STAGE MASTER CYMBAL STAND



HC43BWN

- 25.4mm Diameter Base Section Tubing
- Fine Gear Tilter
- Quick-Set Cymbal Mate
- Boom/Straight Convertible Tilter
- Double Braced Legs
- Boom Arm Length: 400mm (15 3/4")
- Weight: 3.4kg (7.5lbs)
- Height Adjustment Range: 760mm - 1,800mm (30" - 70 13/16")

32.300,00

STAGE MASTER CYMBAL STAND



HC43BSN

- 25.4mm Diameter Base Section Tubing
- Fine Gear Tilter
- Quick-Set Cymbal Mate
- Boom/Straight Convertible Tilter
- Single Braced Legs
- Boom Arm Length: 400mm (15 3/4")
- Weight: 3.4kg (7.7lbs)
- Height Adjustment Range: 760mm - 1,800mm (30" - 70 13/16")

32.300,00

STAGE MASTER CYMBAL STAND



HC42WN

- 25.4mm Diameter Base Section Tubing
- Fine Gear Tilter
- Quick-Set Cymbal Mate
- Double Braced Legs
- Weight: 2.9kg (6.6lbs)
- Height Adjustment Range: 690mm - 1,420mm (27 1/8" - 55 15/16")

28.500,00

STAGE MASTER CYMBAL STAND



HC42SN

- 25.4mm Diameter Base Section Tubing
- Fine Gear Tilter
- Quick-Set Cymbal Mate
- Single Braced Legs
- Weight: 2.7kg (5.15lbs)
- Height Adjustment Range: 690mm - 1,420mm (27 1/8" - 55 15/16")

28.500,00

THE CLASSIC CYMBAL STAND



HC52F

- 19.1mm Diameter Base Section Tubing
- Flat Base Leg Design
- 9mm Diameter Solid Upper Portion
- Fine Gear Tilter
- Compact Folding Design (580mm 22 27/32")
- Weight 1.48kg (3.2lbs)
- Height Adjustment Range: 590mm - 1,300mm (23 1/4" - 51 3/16")

27.700,00

TOM STANDS & TOM HOLDERS

TAMA's tom stands and tom holders feature our original Omni-Ball system which allows each tom to be held securely in place. You can position the drum at virtually any angle simply by loosening one T-nut.

STAR HARDWARE COMBINATION STAND



HTC107W

- 28.6mm Diameter Base Section Tubing
- Swivel-Wing Tom Holder
- Orbital Quick-Tite Cymbal Tilter
- Orbital Quick-Tite Boom Tilter
- Glide-Tite Grip Joint
- True-Sound Insulation Mute
- Ring-True Cymbal Felt
- Boom Arm Length: 300mm (11 3/4")
- Weight: 7.2kg (15.13lbs)

129.000,00

STAR HARDWARE DOUBLE TOM STAND



HTW109W

- 28.6mm Diameter Base Section Tubing
- Swivel-Wing Tom Holder
- Stilt System
- Glide-Tite Grip Joint
- Extra Heavy Double Braced Legs
- Weight: 6.0kg (13lbs)
- Height Adjustment Range: 750mm-1,170mm (29 1/2" – 46")

104.000,00

STAR HARDWARE SINGLE TOM STAND



HTS108W

- For up to 10" Depth Tom Tom
- 28.6mm Diameter Base Section Tubing
- Omni-Ball Tilter
- Glide-Tite Grip Joint
- True-Sound Insulation Mute
- Extra Heavy Double Braced Legs
- Oversized Rubber Feet with Retractable Spike
- Weight: 4.3kg (9.7lbs)
- Height Adjustment Range: 740mm – 1,020mm (29 1/8" – 40 1/8")

88.000,00

ROADPRO COMBINATION STAND



HTC807W

- 28.6mm Diameter Base Section Tubing
- Omni-Ball Tom Angle Adjustment / Movable Tom Positioning
- Quick-Set Tilter
- Quick-Set Cymbal Mate
- Glide-Tite Grip Joint
- Double Braced Legs
- Boom Arm Length: 300mm (11 3/4")
- Weight: 5.4kg (11.14lbs)

84.000,00

ROADPRO COMBINATION STAND



HTC87W

- 28.6mm Diameter Base Section Tubing
- Omni-Ball Tom Angle Adjustment
- Quick-Set Tilter
- Quick-Set Cymbal Mate
- Glide-Tite Grip Joint
- Double Braced Legs
- Boom Arm Length: 300mm (11 3/4")
- Weight: 5.5kg (12.2lbs)

77.000,00

ROADPRO DOUBLE TOM STAND



HTW839W

- 28.6mm Diameter Base Section Tubing
- Omni-Ball Tom Angle Adjustment
- Stilt System
- Glide-Tite Grip Joint
- Double Braced Legs
- Weight: 5.0kg (11lbs)
- Height Adjustment Range: 790-1,270mm (31 1/8" – 50")

96.000,00

ROADPRO DOUBLE TOM STAND



HTW849W

- 28.6mm Diameter Base Section Tubing
- Omni-Ball Tom Angle Adjustment
- Glide-Tite Grip Joint
- Double Braced Legs
- Low Profile Tetrapod
- Weight: 5.1kg (11.3lbs)
- Height Adjustment Range: 550-800mm (21 5/8" – 31 1/2")

104.000,00

ROADPRO SINGLE TOM STAND



HTS88W

- 28.6mm Diameter Base Section Tubing
- Omni-Ball Tom Angle Adjustment
- Glide-Tite Grip Joint
- Double Braced Legs
- Height Adjustment Range: 760mm-1,240mm (30" – 49")
- Weight: 4.2kg (9.25lbs)

52.000,00

STAGE MASTER DOUBLE TOM STAND



HTW49WN

- 25.4mm Diameter Base Section Tubing
- Omni-Ball Tom Angle Adjustment
- Double Braced Legs
- Weight: 3.6kg (7.14lbs)
- Height Adjustment Range: 770-1,200mm (30 5/16" - 47 1/4")

46.000,00

THE CLASSIC TOM STAND



HTS58F

- For 10" to 14" Diameter Drums
- 19.1mm Diameter Base Section Tubing
- Flat Base Leg Design
- Classic Style Basket
- Memory Lock
- Weight: 1.8kg (3.15lbs)
- Height Adjustment Range: 565mm - 820mm (22 1/4" - 32 1/4")
- Storage size: 600mm (23 5/8") (upper section) / 410mm (16 1/8") (lower section)

32.300,00

DOUBLE TOM HOLDER



MTH1000

- 25.4mm Diameter Bass Section Tubing
- Swivel-Wing Tom Holder

MTH1000 (chrome)
MTH1000BN (black nickel)
MTH1000U (smoked black nickel)

87.000,00

DOUBLE TOM HOLDER



MTH800

- 25.4mm Diameter Tubing

71.000,00

DOUBLE TOM HOLDER



MTH600

- 25.4mm Diameter Tubing

MTH600 (chrome)
MTH600BN (black nickel)

42.000,00

SINGLE TOM HOLDER



MTH1000S

- 25.4mm Diameter Bass Section Tubing
- Swivel-Wing Tom Holder

MTH1000S (chrome)
MTH1000SBN (black nickel)
MTH1000SU (smoked black nickel)

77.000,00

SINGLE TOM HOLDER



MTH900BS

- 25.4mm Diameter Bass Section Tubing

61.000,00

SINGLE TOM HOLDER



MTH900BM

- 25.4mm Diameter Tubing

46.000,00

SINGLE TOM HOLDER



MTH800S

- 25.4mm Diameter Tubing

54.000,00

ROADPRO ELECTRONIC PAD STAND



HPS80W

- Glide-Tite Grip Joint
- Double Braced Tripod Base
- Weight: 3.7kg
- Height: 520mm - 1,020mm (20 1/2" - 40 1/8")

42.000,00

HARDWARE KITS

We offer various hardware kit packages to complement any drum sets.

IRON COBRA 900 HARDWARE KIT



HG5WN

- HS800W Roadpro Snare Stand
- HC83BW Roadpro Boom Cymbal Stands (x2)
- HH905D Iron Cobra Hi-hat Stand
- HP900PN Iron Cobra Power Glide Single Pedal

327.000,00

IRON COBRA 600 HARDWARE KIT



HV5WN

- HS80W Roadpro Snare Stand
- HC83BW Roadpro Boom Cymbal Stands (x2)
- HH605 Iron Cobra 600 Hi-hat Stand
- HP600D Iron Cobra 600 Single Pedal

231.000,00

IRON COBRA 200 HARDWARE KIT



HB5W

- HS60W Snare Stand
- HC63BW Boom Cymbal Stands (x2)
- HH205 Iron Cobra 200 Hi-hat Stand
- HP200P Iron Cobra 200 Single Pedal

173.000,00

STAGE MASTER HARDWARE KIT



SM5W

- HS40WN Stage Master Snare Stand
- HC43BWN Stage Master Boom Cymbal Stands (x2)
- HH205 Iron Cobra 200 Hi-hat Stand
- HP200P Iron Cobra 200 Single Pedal

134.000,00

THE CLASSIC STAND HARDWARE KIT



HC4FB

- HS50S Snare Stand
- HC52F Straight Cymbal Stands (x2)
- HH55F Hi-Hat Stand
- SBH01 Hardware Bag

134.000,00

IRON COBRA 200 BUNDLE WITH 1st CHAIR THRONE



HED3R

- HP200P Iron Cobra 200 Single Pedal
- HT230 1st Chair Drum Throne (Round seat)
- HH205S Iron Cobra 200 Hi-hat Stand

119.000,00

IRON COBRA 200 BUNDLE WITH 1st CHAIR THRONE



HED3G

- HP200P Iron Cobra 200 Single Pedal
- HT250 1st Chair Drum Throne (Saddle seat)
- HH205S Iron Cobra 200 Hi-hat Stand

127.000,00

IRON COBRA 200 BUNDLE WITH 1st CHAIR THRONE



HED2R

- HP200P Iron Cobra 200 Single Pedal
- HT230 1st Chair Drum Throne (Round seat)

80.000,00

IRON COBRA 200 BUNDLE WITH 1st CHAIR THRONE



HED2G

-HP200P Iron Cobra 200 Single Pedal
-HT250 1st Chair Drum Throne (Saddle seat)

88.000,00

ROADPRO BOOM STAND 2PCS PACK



HC83BWX2

-HC83BW Roadpro Boom Cymbal Stands (x2)

77.000,00

STAGE MASTER BOOM STAND 2PCS PACK



HC43BWNX2

-HC43BWN Stage Master Boom Cymbal Stands (x2)

61.000,00

THE CLASSIC STAND 2PCS PACK



HC52FX2

-HC52F Straight Cymbal Stands (X2)

50.000,00

POWER TOWER SYSTEM

TAMA's Power Tower System allows you to maintain the same precise set-up time after time. It utilizes 38.1mm stainless round pipes which allow for drums and hardware to be set-up at any angle quickly and easily.

POWER TOWER SYSTEM BASIC UNIT



PMD1100M

- 1100mm Curved Pipe x 1pc
- 850mm Straight Pipe w/19.1mm diameter Joint x 2pc
- 40mm x 20mm x 450mm Square Pipe x 2pc
- Leg Joint Bracket x 2pc
- Rubber Foot x 4pc
- Cross Joint Bracket (J30TS) x 2pc
- Multi Holder (J34T) x 2pc
- Memory Lock (A13S) x 4pc

211.000,00

POWER TOWER SYSTEM ADDITIONAL UNIT



PMD1100A

- 1100mm Curved Pipe x 1pc
- 850mm Straight Pipe w/19.1mm diameter Joint x 1pc
- 40mm x 20mm x 450mm Square Pipe x 1pc
- Leg Joint Bracket x 1pc
- Rubber Foot x 2pc
- Cross Joint Bracket (J30TS) x 2pc
- Multi Holder (J34T) x 1pc
- Memory Lock (A13S) x 3pc

150.000,00

POWER TOWER SYSTEM ADDITIONAL UNIT



PMD900A

- 900mm Curved Pipe x 1pc
- 850mm Straight Pipe w/19.1mm diameter Joint x 1pc
- 40mm x 20mm x 450mm Square Pipe x 1pc
- Leg Joint Bracket x 1pc
- Rubber Foot x 2pc
- Cross Joint Bracket (J30TS) x 2pc
- Multi Holder (J34T) x 1pc
- Memory Lock (A13S) x 3pc

142.000,00

CROSS JOINT BRACKET



J30TS

90 degree perpendicular pipe clamp that allows horizontal and vertical pipes to be set at an equal height.

18.900,00

MULTI HOLDER



J34T

Rack mount for L-rods, tom or cymbal holders. Fits pipes from 10.5mm to 28.6mm in diameter.

18.900,00

MEMORY LOCK



A13S

Memory clamp designed specifically for the Power Tower System.

5.740,00

SINGLE TOM HOLDER



MTH900BS

A single tom holder with 25.4mm diameter base tube.

61.000,00

CLAMPS AND ATTACHMENTS

Back in the 1970's TAMA's original introduction of the multi-clamp was a real revolution in the complex instrument we know as the drum kit. Today, multi-clamps are standard equipment in drums of all brands.

UNIVERSAL CLAMP

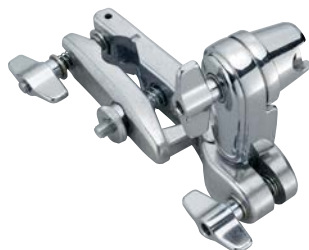

MC66

One side can hold pipes with diameters from 15.9mm to 28.6mm, while the other side is a ratchet holder that can hold a rod from 9mm to 12mm in diameter at various angles. An excellent clamp for adding an array of new set-up possibilities.

18.100,00

UNIVERSAL CLAMP

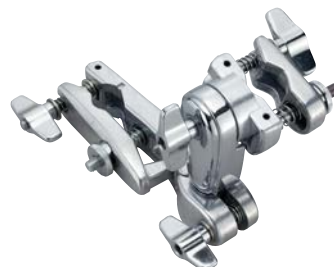

MC67

The heavier duty version of the MC66. One side holds pipes with diameters from 15.9mm to 28.6mm, while the other side is a ratchet holder that can hold a 12mm to 25.4 mm diameter rod or pipe at various angles.

22.300,00

UNIVERSAL CLAMP



MC56

This clamp can be attached to an existing stand pipe that is 15.9mm to 28.6mm in diameter. By attaching a L-Rod or cymbal boom arm that is 9mm to 12mm in diameter, you can easily add a cowbell, woodblock, or cymbal to your drum kit.

14.600,00

MULTI-CLAMP



MC61

A basic clamp for connecting stands with pipes from 15.9mm to 28.6mm in diameter with any attachment having a 19.1mm diameter pipe.

12.300,00

MULTI-CLAMP



MC62

A double multi-clamp for connecting two pipes from 15.9mm to 28.6mm in diameter. Both sides feature the FastClamp Easy Set-Up System.

17.300,00

COMPACT CLAMP



MC7

Same function as the MC5, but with even greater flexibility. The ratchet holder section can hold any diameter tube from 12mm to 25.4mm.

17.300,00

HOOP GRIP



MC8

The Hoop Grip is a simple tool that allows you to add cymbals or other accessories to your drum kit to expand your setup and customize your sound.

-available on Steel Hoops and Die-Cast Hoops.
*NOT available on Wood Hoops.

13.500,00

HOOP GRIP FOR BASS DRUM



MC9

The MC9 Hoop Grip for bass drum is a simple clamp. However, when combined with an L-Rod or Z-Rod, you can set splash cymbal or various percussion items on the bass drum.

14.600,00

Z-ROD FOR COWBELL



ZCB

Z-rod for mounting cowbell or other percussion instruments and accessories (9mm diameter)

7.320,00

Z-ROD FOR SPLASH CYMBAL -LONG



ZCYEL

Z-rod for mounting lightweight cymbals (10.5mm diameter)

Details:
- Quick-set cymbal mate

10.000,00

Z-ROD FOR SPLASH CYMBAL -SHORT



ZCYE

Z-rod for mounting lightweight cymbals (10.5mm diameter)

Details:
- Quick-set cymbal mate

9.630,00

HOOP GRIP & ACCESSORY MOUNT ARM



MC8HCA20

Hoop Grip (MC8) & Accessory Mount Arm bundle package

22.700,00

CLOSED HI-HAT ATTACHMENT



MXA43

This closed hi-hat attachment utilizes a specially designed screw clutch, allowing for quick, easy, and precise adjustments. The space between the hi-hat cymbals can be adjusted by rotating the screw clutch clockwise or counterclockwise.

28.500,00

CLOSED HI-HAT ATTACHMENT



MXA53

Simply designed closed hi-hat attachment that allows for two different settings by turning a lever. Attachable to stands from 15.9mm to 28.6mm in diameter. Great for double bass or double pedal players.

37.300,00

CLOSED HI-HAT ATTACHMENT



MXA73N

The tension adjustment knob makes it possible to finely adjust the degree of opening of the hi-hat cymbals. In addition, the angle of the bottom cymbal is also adjustable.

- Quick-set hi-hat clutch
- Quick-set tilter

52.000,00

ELECTRONIC PAD HOLDER



MPH63

The MPH63 is a Fast-Clamp attachment for an electronic pad. Combining TAMA's MC66 universal clamp and the electronic pad stand boom arm, you can attach an electronic pad to any stand that has a 15.9mm to 28.6mm diameter pipe.

34.300,00

L-ROD FOR TOM TOM



LLT

L-rod for mounting toms (10.5mm diameter).

6.550,00

L-ROD FOR COWBELL



LCB

L-rod for mounting different hand percussion instruments and accessories. The 9mm diameter rod fits most popular percussion instruments designed for attachment to a 3/8" rod.

6.160,00

L-ROD FOR CYMBAL



LCYE

L-rod for mounting lightweight cymbals.

Details:
- Quick-set cymbal mate

7.320,00

L-ROD FOR HI-HAT CYMBAL



LHH

L-Rod for Hi-hat cymbals.

Details:
- Screw-Type Hi-hat clutch

18.900,00

HAT STACK



CSH5

- Easily attach a small cymbal to hi-hat rod measuring up to 7mm in diameter
- Compact size and lightweight for easy transport and storage - 25mm (1") diameter x 40mm (1.5") height
- Ability to adjust cymbal sustain

5.740,00

CYMBAL STACKER



CSA15

The CSA15 is a straight-forward cymbal stacker useful for adding small cymbals to your setup using the M8 threaded cymbal rod.

10.000,00

CYMBAL STACKER



CSA25

The CSA25 allows positioning of a small cymbal on the M8 threaded cymbal rod, as well as independent angle adjustment.

18.900,00

BOOM ARM



MCB30EN

MCB30EN can be used in combination with a ratchet arm or the MC66 universal clamp is available.

Details:
- 300mm (11 3/4") length
- Quick-set tilter
- Quick-set cymbal mate

17.700,00

BOOM ARM



MCB45EN

MCB45EN can be used in combination with a ratchet arm or the MC66 universal clamp is available.

Details:
- 450mm (17 3/4") length
- Quick-set tilter
- Quick-set cymbal mate

18.900,00

CYMBAL HOLDER



CACLJ

Bass Drum Mounted Cymbal Holder features telescoping arm & fine gear tilter, which allow you to adjust the angle and height of the cymbal as you like in smaller spaces.

17.300,00

CYMBAL HOLDER



CA30EN

Details:
- 300mm (11 3/4") length
- Quick-set tilter
- Quick-set cymbal mate

33.500,00

CYMBAL HOLDER



CA45EN

Details:
- 450mm (17 3/4") length
- Quick-set tilter
- Quick-set cymbal mate

35.800,00

CYMBAL ATTACHMENT



CCA30

The assortment of boom cymbal holder and MC61 multi-clamp. By connecting to stands from 15.9mm to 28.6mm in diameter, you can add any cymbal easily.

33.500,00

CYMBAL ATTACHMENT



MCA53

The MCA53 is a simplified attachment based on the functionality of the MCA63EN. Add cymbals by securing this attachment to stands from 15.9mm to 28.6mm in diameter.

23.500,00

CYMBAL ATTACHMENT



MCA63EN

Combines the MC66 universal clamp and the MCB30EN boom arm. Works perfectly for adding cymbals and accessories to stands with pipes from 15.9mm to 28.6mm in diameter.

Details:
- Quick-set tilter
- Quick-set cymbal mate

34.300,00

CYMBAL ATTACHMENT



CYA5E

Combines the MC5 compact clamp with the LCYE L-rod for mounting one cymbal to one boom arm. Can be clamped to rods from 9mm to 12mm in diameter or to the L-rod of a tom holder.

Details: Quick-set cymbal mate

18.900,00

TOM ATTACHMENT



MC69

Clamping this attachment on a 15.9mm to 28.6mm diameter pipe allows for direct set-up of toms. Even with a compact construction, the inclusion of the Omni-ball feature at the angle adjustment point lets you adjust toms to any angle.

23.500,00

TOM ADAPTER



MTH900AS

This adapter allows you to add single toms to stands using the flexibility and speed of TAMA's Omni-Ball/L-rod combination.

18.900,00

COWBELL ATTACHMENT



CBA5

Compact attachment for mounting hand percussion such as cowbells or tambourines. Combines the MC5 compact clamp and the LCB L-rod to provide set-up flexibility. The 3/8" L-rod fits most popular percussion instruments and accessories.

16.900,00

COWBELL ATTACHMENT



CBA56

Combines the universal clamp with the LCB L-rod to mount most popular percussion instruments and accessories. Can be attached to pipes ranging from 15.9 mm to 28.6 mm in diameter.

17.700,00

COWBELL ATTACHMENT



CBH20

This simple attachment allows cowbells to be mounted on the bass drum. The length and angle of the L-rod can be easily changed for optimum positioning.

12.300,00

COWBELL ATTACHMENT



CBH50

The position and angle of the cowbell are adjustable to your preference. The bass drum clamp is now equipped with rubber hoop protectors in order to prevent the hoop from becoming damaged.

17.300,00

HI-HAT ATTACHMENT



MHA823

This hi-hat attachment allows for better positioning of a hi-hat stand while using a double bass drum set-up. By connecting the MHA823 to the bass drum hoop, the hi-hat stand can be held upright without opening the hi-hat stand's legs. By utilizing TAMA Omni-Ball system, the clamp is now infinitely adjustable to any angle and enables even greater set-up flexibility. As well, rubber cushions are equipped to protect bass drum hoop from becoming damaged. The clamp is attachable to any hi-hat stand with a pipe diameter of 15.9 - 28.6mm by using the FastClamp Easy Set-Up System.

37.300,00

CYMBAL ATTACHMENT KIT



MCAX5366

A cymbal attachment kit is available for the Cocktail-JAM. These attachments have been simplified for portability. The hi-hat attachment allows you to open or close the hi-hats by simply flipping a lever.

- MCA53 cymbal attachment
- MCA56 closed hi-hat attachment

54.000,00

MICROPHONE STANDS

Just as many years ago, TAMA single-handedly altered the essence of the modern drum set through its re-invention of drum hardware—TAMA now turns that same degree of engineering dedication to yet another unevolved category of music gear: the microphone stand.

IRON WORKS STUDIO TELESCOPING BOOM STAND



MS737BK

- Vice-Grip Boom Tilter
 - Sure-Cast Adjustment Collar
 - Die-Cast Locking Thumb Nut
 - Silent T-Handle
 - Latch-Lok Sleeve Insert
- Height: 995mm – 1,665mm (39 3/16" - 65 1/2")
 Boom Arm: 1,055mm (41 1/2")
 Weight: 5.75kg
 Black Finish

50.000,00

IRON WORKS STUDIO TELESCOPING BOOM STAND



MS736BK

- Vice-Grip Boom Tilter
 - Iron-Core Legs with Vibration-Isolating Rubber Feet
 - Iron-Core Telescoping Boom Arm
 - Silent T-Handle
 - Detachable Boom Arm
- Height: 975-1650mm (38 3/8"-64 15/16")
 Boom arm : 505-850mm (19 7/8"-33 7/16")
 Weight : 5.4kg (11.9lbs)
 Black Finish

50.000,00

IRON WORKS STUDIO LOW PROFILE TELESCOPING BOOM STAND



MS736LBK

- Vice-Grip Boom Tilter
 - Iron-Core Legs with Vibration-Isolating Rubber Feet
 - Iron-Core Telescoping Boom Arm
 - Silent T-Handle
 - Detachable Boom Arm
- Height : 440mm - 605mm (17 5/16" - 23 13/16")
 Boom arm : 505mm - 850mm (19 7/8" - 33 7/16")
 Weight : 4.7kg (10.4lbs)
 Black Finish

50.000,00

IRON WORKS STUDIO ROUND BASE TELESCOPING BOOM STAND



MS736RBK

- Vice-Grip Boom Tilter
 - Sure-Cast Adjustment Collar
 - Die-Cast Locking Thumb Nut
 - Round Cast Base
 - Silent T-Handle
 - Latch-Lok Sleeve Insert
 - Iron-Core Telescoping Boom Arm
- Height: 990-1700mm (38 3/8"-64 15/16")
 Weight: 8.2kg
 Black Finish

50.000,00

IRON WORKS STUDIO ROUND BASE EXTRA LOW PROFILE TELESCOPING BOOM STAND



MS736RELBK

- Vice-Grip Boom Tilter
 - Iron-Core Telescoping Boom Arm
 - Silent T-Handle
 - Detachable Boom Arm
 - Heavy Round Cast Base
- Height : 280mm (11 1/32")
 Boom arm : 505mm - 850mm (19 7/8" - 33 7/16")
 Weight : 7.7kg (17.0lbs)
 Black Finish

50.000,00

IRON WORKS STUDIO SERIES EXTRA LOW TELESCOPING BOOM STAND



MS734ELBK

- Vice-Grip Boom Tilter
 - Die-Cast Locking Thumb Nut
 - Silent T-Handle
 - Iron-Core Telescoping Boom Arm
- Height: 325mm (12 3/4")
 Boom arm: 335mm - 520mm (13 1/8" - 20 1/2")
 Weight: 4kg (8.8lbs)
 Black Finish

50.000,00

IRON WORKS TOUR TELESCOPING BOOM STAND



MS436BK

- Cast Grip Boom Tilter
- Die-Cast Locking Thumb Nut
- Sure-Cast Adjustment Collar
- Iron-Core Telescoping Boom Arm
- Detachable Boom Arm

Height : 985mm – 1660mm (38 3/4" – 65 3/8")
 Boom arm : 845mm (33 1/4")
 Weight : 3.9kg (8.6lbs)
 Black Finish

38.100,00

IRON WORKS TOUR LOW PROFILE TELESCOPING BOOM STAND



MS436LBK

- Cast Grip Boom Tilter
- Die-Cast Locking Thumb Nut
- Sure-Cast Adjustment Collar
- Iron-Core Telescoping Boom Arm
- Detachable Boom Arm

Height : 440mm – 605mm (17 5/16" – 23 13/16")
 Boom arm : 505mm (19 7/8" – 33 1/4")
 Weight : 3.1kg (6.9lbs)
 Black Finish

38.100,00

IRON WORKS TOUR TABLE TOPSTAND



MS30BK

- Lighter Smaller Zinc Die-Cast Round Base
- 2 stage Aluminum Pipe Construction

Height: 220mm - 370mm (8 5/8"-14 9/16")
 Weight: 1.1kg
 Black Finish

15.000,00

BOOM STAND



MS205

- Cast Grip Boom Tilter

Height : 960mm – 1600mm (37 13/16" – 63")
 Boom arm : 830mm (32 11/16")
 Weight : 3.2kg (7.1 lbs)
 Chrome Finish

31.600,00

BOOM STAND



MS205BK

- Cast Grip Boom Tilter

Height : 960mm – 1600mm (37 13/16" – 63")
 Boom arm : 830mm (32 11/16")
 Weight : 3.2kg (7.1 lbs)
 Black Finish

31.600,00

BOOM STAND



MS205VBK

- Vice-Grip Boom Tilter
- Latch-Lok Sleeve Insert

Height: 965mm – 1,600mm (38" - 63")
 Boom Arm : 830mm (32 11/16")
 Weight: 3.26kg (7.1lbs)
 Black Finish

46.000,00

LOW PROFILE BOOM STAND



MS205ST

- Cast Grip Boom Tilter

Height : 430mm – 560mm (17 1/8" – 22 1/16")
 Boom arm : 510mm (20 1/16")
 Weight : 2.3kg (5.1 lbs)
 Chrome Finish

26.600,00

LOW PROFILE BOOM STAND



MS205STBK

- Cast Grip Boom Tilter

Height : 430mm – 560mm (17 1/8" – 22 1/16")
 Boom arm : 510mm (20 1/16")
 Weight : 2.3kg (5.1 lbs)
 Black Finish

26.600,00

STRAIGHT STAND



MS200BK

Height : 910 - 1550mm (36" - 61")
 Weight : 2.4kg (5.4lbs)
 Black Finish

24.600,00

STRAIGHT STAND WITH ROUND BASE



MS200DBK

- Cast Round Base with T-Bolt Pipe Fixing Device

Height : 895 - 1510mm (35 1/4" - 59 7/16")
 Weight : 3.8kg (8.6lbs)
 Black Finish

26.600,00

DESK-MOUNTED MICROPHONE BOOM ARM



MSDA206BK

-Iron-Core Telescoping Boom Arm
-Cast Grip Boom Tilter
-Height memory lock
-Headset hanging hook
Height: 95 - 515mm (3 3/4" - 20 1/4")
Boom Arm: 450 - 800mm (17 3/4" - 31 1/2")
Weight : 1.6kg (3.6lbs)
Black Finish

38.100,00

MICROPHONE TELESCOPING BOOM ARM WITH CLAMP



MSCA734BK

NEW

-Iron-Core Telescoping Boom Arm
-Vice-Grip Boom Tilter
-Clamp holds pipes with diameters from 15-25.4mm (5/8"-1")
Boom Arm: 290-455mm (11 7/16"-17 15/16")
Weight : 0.87kg (1.9lbs)
Black Finish

30.400,00

BOOM ARM



MS736BB

Vice-Grip Boom Tilter with Iron-Core Telescoping Boom Arm

28.500,00

BOOM ARM



MS436BB

Cast-Grip Boom Tilter with Iron-Core Telescoping Boom Arm

24.600,00

TRI-LIFT ADAPTER



TLA3

An extremely innovative product, the TLA3 Tri-Lift Adaptor is highly useful for setting multiple microphone stands very close together. This adaptor lifts the mic stand's legs up and enables you to place another stand's legs underneath. (3pcs/Set)

2.660,00

CORD CLIP



CC5

For 15.9 mm (5/8") diameter tube. (3pcs/Set)

2.660,00

CORD CLIP



CC7

For 22.2 mm (7/8") diameter tube. (3pcs/Set)

2.660,00

DIE-CAST LOCKING THUMB NUT



DTLN3

For 3/8" connector
Not only does the thumb nut's larger, sure-grip design allow greater leverage for faster, easier set-up and breakdown, its high quality zinc threads and walls are built to handle pressure for years to come.

2.660,00

RUBBER FOOT



756-RF

TAMA's extra thick rubber foot covers "float" the stand, isolating the microphone from floor vibrations. (for 19.1mm diameter leg)

2.660,00

GUITAR STAND



839

-Adjustable Neck and Body Holder
-Glide-Tite Grip Joint
-Die-Cast Tripod Base

38.100,00

TAMA PERCUSSION

For more than 40 years, TAMA has been inspiring drummers around the world with its unique range of original percussion instruments. Combining the influences of global musical cultures with modern technology, TAMA has given drummers and percussionists of every genre a new lease on creativity with the unique voices these instruments provide.

GONG BASS DRUM



MAG20R

20"x14" Starclassic Maple Gong Bass Drum

MEG20R (Exotic Finishes)
MAG20R (Lacquer Finishes)
MRG20R (Duracover Finishes)

*Gong Bass Drums is available in all Starclassic Maple finishes (Exotic/ Lacquer / Duracover Wrap).
**Gong Bass Drums Shell Hardware is available in Chrome finish only.
***Hardware and tom arms not included.

500.000,00

METALWORKS "EFFECT" STEEL MINI-TYMP



MT68STBK

6"x4" + 8"x4"

Steel Mini-Tymp come with an L-rod (LLT) and multi-clamp (MC66).

84.000,00

METALWORKS "EFFECT" STEEL MINI-TYMP



MT810STBK

8"x4" + 10"x4"

Steel Mini-Tymp come with an L-rod (LLT) and multi-clamp (MC66).

88.000,00

JINGLE RING



TJR7

The Jingle Ring is a slim tambourine that can be mounted on a hi-hat stand or as a separate item. It features 9 pairs of nickel "jingles" that produce a bright, clear, tambourine sound.

18.900,00

OCTOBAN SET



7850N2H

2pc High-pitch set w/HOW29WN stand

208.000,00

OCTOBAN SET



7850N2L

2pc Low-pitch set w/HOW29WN stand

250.000,00

OCTOBAN SET



7850N4H

4pc High-pitch set w/HOW49WN stand

373.000,00

OCTOBAN SET



7850N4L

4pc Low-pitch set w/HOW49WN stand

458.000,00

OCTOBAN



OCT280N

280mm (11") depth

73.000,00

OCTOBAN



OCT301N

301mm (11 3/4") depth

77.000,00

OCTOBAN



OCT343N

343mm (13 1/2") depth

80.000,00

OCTOBAN



OCT390N

390mm (15 1/2") depth

84.000,00

OCTOBAN



OCT443N

443mm (17 1/2") depth

96.000,00

OCTOBAN



OCT472N

472mm (18 1/2") depth

100.000,00

OCTOBAN



OCT536N

536mm (21") depth

104.000,00

OCTOBAN



OCT600N

600mm (23 1/2") depth

111.000,00

OCTOBAN STAND



HOW29WN

for 2pcs octobans

73.000,00

OCTOBAN STAND



HOW49WN

for 4pcs octobans

80.000,00

OCTOBAN HOLDER FOR DRUM RACK



OA29

for 2pcs octobans

30.400,00

OCTOBAN HOLDER FOR DRUM RACK



OA49

for 4pcs octobans

34.300,00

PRACTICE TOOLS

Our unique practice tools make your percussive education more enjoyable and productive.

PRACTICE PAD



TSP9

This practice pad accurately imitates the natural feel & rebound of an acoustic snare drum. The wooden base and 6mm thick rubber playing surface offer excellent durability. This combination provides easy control and is ideal for hours long practice sessions.

The non-slip base allows the practice pad to rest on a tabletop or snare drum without damaging the surface beneath.

- Unique Playing Surface
- A Natural Feel with the Perfect Bounce

13.400,00

PRACTICE PAD STAND



HS40TPN

The HS40TPN practice pad stand can hold pads between 6 and 10 inches in diameter. The EP222 Extension Pipe sold separately.

- Single Braced Legs
- Height Adjustment Range w/o extension pipe: 580mm - 710mm (22 13/16" - 27 15/16")
- w/ extension pipe (EP222): 790mm - 1,065mm (31 1/8" - 41 15/16")

28.500,00

EXTENSION PIPE FOR PRACTICE PAD STAND



EP222

The height of the HS40TPN can be easily extended by attaching the EP222 extension pipe between the upper and lower section of unit. No tools are required to install this product.

9.590,00

MESH HEAD



MH8T

MH8T (8")	4.580,00
MH10T (10")	4.970,00
MH12T (12")	5.350,00
MH13T (13")	5.740,00
MH14T (14")	6.120,00
MH16T (16")	6.510,00
MH18B (18")	7.660,00
MH22B (22")	11.900,00

SOFT SOUND BEATER



BSQ10S

Soft Sound Beater provides a significant decrease in volume, but allows you to use your regular bass drum pedal and bass drum head with a natural and accurate feel.

13.400,00

SOFT SOUND BEATER



BSQ5S

Soft Sound Beater provides a significant decrease in volume, but allows you to use your regular bass drum pedal and bass drum head with a natural and accurate feel.

- Half size version for twin pedal users

11.500,00

SOFT SOUND RING



SSR8

The TAMA Soft Sound Ring is made of 6mm thick foam rubber. This drum accessory reduces the volume of an acoustic drum kit while retaining the natural tone of the shell.

SSR8 (8")	5.350,00
SSR10 (10")	6.120,00
SSR12 (12")	7.660,00
SSR13 (13")	9.200,00
SSR14 (14")	10.400,00
SSR16 (16")	11.500,00

SOFT SOUND PACKAGE



SSRP52K

22"BD 5pc kit configuration

The Soft Sound package reduces the volume of an acoustic drum kit while retaining the natural tone of the shell. It is designed to maintain the feel of playing an acoustic drum kit; a very important feature when playing in low volume situations.

-10", 12", 14", and 16" Soft Sound Ring
-Half Soft Sound Beater (BSQ5S)

36.500,00

SOFT SOUND PACKAGE



SSRP50

20"BD 5pc kit configuration

The Soft Sound package reduces the volume of an acoustic drum kit while retaining the natural tone of the shell. It is designed to maintain the feel of playing an acoustic drum kit; a very important feature when playing in low volume situations.

-10", 12", and 2pcs of 14" Soft Sound Ring
-Half Soft Sound Beater (BSQ5S)

36.500,00

SOFT SOUND PACKAGE

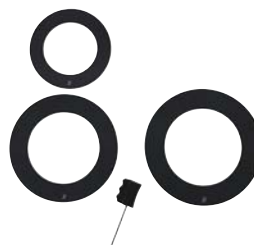

SSRP48

18"BD 4pc kit configuration

The Soft Sound package reduces the volume of an acoustic drum kit while retaining the natural tone of the shell. It is designed to maintain the feel of playing an acoustic drum kit; a very important feature when playing in low volume situations.

-10", 13", and 14" Soft Sound Ring
-Half Soft Sound Beater (BSQ5S)

30.800,00

CYMBAL MUTE



CM14HH

for 14" hi-hat cymbal

9.590,00

CYMBAL MUTE



CM1416

for 14" or 16" cymbal

4.970,00

CYMBAL MUTE



CM1820

for 18" or 20" cymbal

5.350,00

SILENT PRACTICE SET

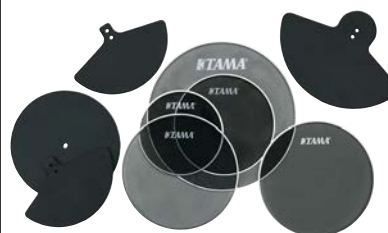

SPP518CN

Mesh head for 18" bass drum
Mesh head for 10" tom tom
Mesh head for 12" tom tom
Mesh head for 14" floor tom & snare drum (x2)
Cymbal mute for 14" hi-hat cymbal
Cymbal mute for 14" or 16" cymbal
Cymbal mute for 18" or 20" cymbal

42.000,00

SILENT PRACTICE SET



SPP522C

Mesh head for 22" bass drum
Mesh head for 12" tom tom
Mesh head for 13" tom tom
Mesh head for 16" floor tom
Mesh head for 14" snare drum
Cymbal mute for 14" hi-hat cymbal
Cymbal mute for 14" or 16" cymbal
Cymbal mute for 18" or 20" cymbal

46.000,00

SILENT PRACTICE SET



SPP522KC

Mesh head for 22" bass drum
Mesh head for 10" tom tom
Mesh head for 12" tom tom
Mesh head for 16" floor tom
Mesh head for 14" snare drum
Cymbal mute for 14" hi-hat cymbal
Cymbal mute for 14" or 16" cymbal
Cymbal mute for 18" or 20" cymbal

46.000,00

SILENT TIPS



TCP20

TAMA TCP20 is a pair of silicone rubber tips that fit over most drum stick models. These tips make it easy and convenient to practice silently, anytime, anywhere.

1.620,00

ISO-BASE SOUND REDUCTION PAD SET



TIBS4

Designed for quiet practice at home, the Iso-Base Sound Reduction Pads offer superb floor vibration isolation. For use with cymbal stands, bass drum pedals, hi-hat stands, and even bass drum spurs, the Iso-Base pads are compact and lightweight for easy set-up, tear down, and portability.

- Including TIBP1 x 1 and TIBL1 x 3

38.100,00

ISO-BASE SOUND REDUCTION PEDAL PAD



TIBP1

The Pedal Pad offer bass drum pedal floor vibration isolation during home practice.

30.400,00

ISO-BASE SOUND REDUCTION LEG PAD



TIBL1

The Leg Pads offer floor vibration isolation during home practice for cymbal stands, hi-hat stands, and bass drum spurs.

4.970,00

BAGS

POWERPAD® BAG -Tom Tom-



PBT8

PBT8 (8"x7" Tom Tom)
PBT10 (10"x8" Tom Tom)
PBT12 (12"x9" Tom Tom)
PBT13 (13"x10" Tom Tom)

17.700,00

POWERPAD® BAG -Floor Tom-



PBF14

PBF14 (14"x14" Floor Tom)
PBF16 (16"x16" Floor Tom)

30.400,00

POWERPAD® BAG -Bass Drum-



PBB18

PBB18 (18"x16" Bass Drum or Floor Tom)
PBB20 (20"x18" Bass Drum)
PBB22 (22"x18" Bass Drum)
PBB24 (24"x18" Bass Drum)

42.000,00

POWERPAD® BAG -Snare Drum-



PBS1455

PBS1445 (14"x4.5" Snare Drum)
PBS1455 (14"x5.5" Snare Drum)
PBS1465 (14"x6.5" Snare Drum)
PBS1480 (14"x8" Snare Drum)

22.700,00

POWERPAD® BAG -Hardware-



PBH02L

880 (L) x 150 (W) x 200 (H) mm
(34 5/8" x 5 7/8" x 7 7/8")

-Suitable size for storing about 5 stand

22.700,00

POWERPAD® BAG -Hardware-



PBH05

850 (L) x 320 (W) x 220 (H) mm
(33 1/2" x 12 5/8" x 8 5/8")

-Suitable size for storing about 10 stands
-Equipped with durable wheels

74.000,00

POWERPAD® BAG -Cymbal-



PBC22

The POWERPAD® Series Cymbal Bag is a heavy duty bag designed to carry cymbals up to 22" in diameter. The main compartment contains (3) 22" dividers and the front side pocket contains (3) 15" dividers.

40.000,00

POWERPAD® BAG -Twin Pedal-



PBP200

The PBP200 can accommodate both single and double pedals.

450 (L) x 300 (W) x 200 (H) mm
(17 3/4" x 11 7/8" x 7 7/8")

23.500,00

POWERPAD® BAG -Single Pedal-



PBP100

The POWERPAD® Series bag for single pedal.

220 (D) x 190 (W) x 400 (H) mm
(8 5/8" x 7 1/2" x 15 3/4")

11.600,00

POWERPAD® BAG -Drum Throne-



PBTH15

-Carries any TAMA drum throne
-Carries 14" snare drum and snare drum stand
-Shoulder strap and handle for easy transportation

29.300,00

POWERPAD® BAG -Stick & Mallet-



PBS50

Stores about 24 pairs of sticks & mallets

-Large front pocket for sheet music
-Built-in hooks easily attach to floor tom
-Padded Shoulder strap
-Convenient inner pockets
-Height: 500mm
-Open Width: 580mm

22.700,00

POWERPAD® BAG -Stick-



PBS24

Stores about 12 pairs of sticks & mallets

14.200,00

POWERPAD® DESIGNER BAG -Drum Set-



TDSS52KBK

Black
22"x18" Bass Drum
10"x8" Tom Tom
12"x9" Tom Tom
16"x16" Floor Tom
14"x6.5" Snare Drum

-10mm thick inner cushions
-Ergonomic rubber handle
-A comfortable padded shoulder strap (for the snare drum bag)

92.000,00

POWERPAD® DESIGNER BAG -Drum Set-



TDSS52KBE

Beige
22"x18" Bass Drum
10"x8" Tom Tom
12"x9" Tom Tom
16"x16" Floor Tom
14"x6.5" Snare Drum

-10mm thick inner cushions
-Ergonomic rubber handle
-A comfortable padded shoulder strap (for the snare drum bag)

92.000,00

POWERPAD® DESIGNER BAG -Drum Set-



TDSS52KMG

Moss Green
22"x18" Bass Drum
10"x8" Tom Tom
12"x9" Tom Tom
16"x16" Floor Tom
14"x6.5" Snare Drum

-10mm thick inner cushions
-Ergonomic rubber handle
-A comfortable padded shoulder strap (for the snare drum bag)

92.000,00

POWERPAD® DESIGNER BAG -Drum Set-



TDSS52KNB

Navy Blue
22"x18" Bass Drum
10"x8" Tom Tom
12"x9" Tom Tom
16"x16" Floor Tom
14"x6.5" Snare Drum

-10mm thick inner cushions
-Ergonomic rubber handle
-A comfortable padded shoulder strap (for the snare drum bag)

92.000,00

POWERPAD® DESIGNER BAG -Drum Set-



TDSS52KWR

Wine Red
22"x18" Bass Drum
10"x8" Tom Tom
12"x9" Tom Tom
16"x16" Floor Tom
14"x6.5" Snare Drum

-10mm thick inner cushions
-Ergonomic rubber handle
-A comfortable padded shoulder strap (for the snare drum bag)

92.000,00

POWERPAD® DESIGNER BAG -8" Tom Tom-



TSBT8BK

Black
8"x7" Tom Tom

-10mm thick inner cushions
-Ergonomic rubber handle

9.590,00

POWERPAD® DESIGNER BAG -8" Tom Tom-



TSBT8BE

Beige
8"x7" Tom Tom

-10mm thick inner cushions
-Ergonomic rubber handle

9.590,00

POWERPAD® DESIGNER BAG -8" Tom Tom-



TSBT8MG

Moss Green
8"x7" Tom Tom

-10mm thick inner cushions
-Ergonomic rubber handle

9.590,00

POWERPAD® DESIGNER BAG -8" Tom Tom-



TSBT8NB

Navy Blue
8"x7" Tom Tom

-10mm thick inner cushions
-Ergonomic rubber handle

9.590,00

POWERPAD® DESIGNER BAG -8" Tom Tom-



TSBT8WR

Wine Red
8"x7" Tom Tom

-10mm thick inner cushions
-Ergonomic rubber handle

9.590,00

POWERPAD® DESIGNER BAG -14" Floor Tom-



TSBF14BK

Black
14"x14" Tom Tom

-10mm thick inner cushions
-Ergonomic rubber handle

14.600,00

POWERPAD® DESIGNER BAG -14" Floor Tom-



TSBF14BE

Beige
14"x14" Tom Tom

-10mm thick inner cushions
-Ergonomic rubber handle

14.600,00

POWERPAD® DESIGNER BAG -14" Floor Tom-



TSBF14MG

Moss Green
14"x14" Tom Tom

- 10mm thick inner cushions
- Ergonomic rubber handle

14.600,00

POWERPAD® DESIGNER BAG -14" Floor Tom-



TSBF14NB

Navy Blue
14"x14" Tom Tom

- 10mm thick inner cushions
- Ergonomic rubber handle

14.600,00

POWERPAD® DESIGNER BAG -14" Floor Tom-



TSBF14WR

Wine Red
14"x14" Tom Tom

- 10mm thick inner cushions
- Ergonomic rubber handle

14.600,00

POWERPAD® DESIGNER BAG -Snare Drum-



TSDB1465BK

Black
14"x6.5" Snare Drum

- Convertible Backpack Straps
- 20mm thick semi-hard cushion
- Backpack Straps and ergonomic rubber handle

25.800,00

POWERPAD® DESIGNER BAG -Snare Drum-



TSDB1465BE

Beige
14"x6.5" Snare Drum

- Convertible Backpack Straps
- 20mm thick semi-hard cushion
- Backpack Straps and ergonomic rubber handle

25.800,00

POWERPAD® DESIGNER BAG -Snare Drum-



TSDB1465MG

Moss Green
14"x6.5" Snare Drum

- Convertible Backpack Straps
- 20mm thick semi-hard cushion
- Backpack Straps and ergonomic rubber handle

25.800,00

POWERPAD® DESIGNER BAG -Snare Drum-



TSDB1465NB

Navy Blue
14"x6.5" Snare Drum

- Convertible Backpack Straps
- 20mm thick semi-hard cushion
- Backpack Straps and ergonomic rubber handle

25.800,00

POWERPAD® DESIGNER BAG -Snare Drum-



TSDB1465WR

Wine Red
14"x6.5" Snare Drum

- Convertible Backpack Straps
- 20mm thick semi-hard cushion
- Backpack Straps and ergonomic rubber handle

25.800,00

POWERPAD® DESIGNER BAG -Hardware-



THB02LBK

Black
880 (L) x 150 (W) x 200 (H) mm
(34 5/8" x 5 7/8" x 7 7/8")

- Suitable size for storing about 4 stands

18.800,00

POWERPAD® DESIGNER BAG -Hardware-



THB02LBE

Beige
880 (L) x 150 (W) x 200 (H) mm
(34 5/8" x 5 7/8" x 7 7/8")

- Suitable size for storing about 4 stands

18.800,00

POWERPAD® DESIGNER BAG -Hardware-



THB02LMG

Moss Green

880 (L) x 150 (W) x 200 (H) mm
(34 5/8" x 5 7/8" x 7 7/8")

-Suitable size for storing about 4 stands

18.800,00

POWERPAD® DESIGNER BAG -Hardware-



THB02LNB

Navy Blue

880 (L) x 150 (W) x 200 (H) mm
(34 5/8" x 5 7/8" x 7 7/8")

-Suitable size for storing about 4 stands

18.800,00

POWERPAD® DESIGNER BAG -Hardware-



THB02LWR

Wine Red

880 (L) x 150 (W) x 200 (H) mm
(34 5/8" x 5 7/8" x 7 7/8")

-Suitable size for storing about 4 stands

18.800,00

POWERPAD® DESIGNER BAG -Hardware-



THB04XLBK

Black

880 (L) x 180 (W) x 250 (H) mm
(34 5/8" x 7 1/16" x 9 13/16")

-Suitable size for storing HV5WN hardware kit
without drum pedal
(2-HC83BW, HS80W, HH605)

23.100,00

POWERPAD® DESIGNER BAG -Cymbal-



TCB22BK

Black

up to 22" Cymbal + 15" Cymbal (front side pocket)

-20mm thick semi-hard cushion
-Padded shoulder Straps and handle
-22" compartment dividers (3pcs) and 15"
compartment dividers (3pcs) included

33.800,00

POWERPAD® DESIGNER BAG -Cymbal-



TCB22BE

Beige

up to 22" Cymbal + 15" Cymbal (front side pocket)

-20mm thick semi-hard cushion
-Padded shoulder Straps and handle
-22" compartment dividers (3pcs) and 15"
compartment dividers (3pcs) included

33.800,00

POWERPAD® DESIGNER BAG -Cymbal-



TCB22MG

Moss Green

up to 22" Cymbal + 15" Cymbal (front side pocket)

-20mm thick semi-hard cushion
-Padded shoulder Straps and handle
-22" compartment dividers (3pcs) and 15"
compartment dividers (3pcs) included

33.800,00

POWERPAD® DESIGNER BAG -Cymbal-



TCB22NB

Navy Blue

up to 22" Cymbal + 15" Cymbal (front side pocket)

-20mm thick semi-hard cushion
-Padded shoulder Straps and handle
-22" compartment dividers (3pcs) and 15"
compartment dividers (3pcs) included

33.800,00

POWERPAD® DESIGNER BAG -Cymbal-



TCB22WR

Wine Red

up to 22" Cymbal + 15" Cymbal (front side pocket)

-20mm thick semi-hard cushion
-Padded shoulder Straps and handle
-22" compartment dividers (3pcs) and 15"
compartment dividers (3pcs) included

33.800,00

POWERPAD® DESIGNER BAG -Cajon-



TCB01BK

Black

330 (L) x 310 (W) x 520 (H) mm
(13" x 12 1/4" x 20 1/2")

-Backpack straps

30.000,00

POWERPAD® DESIGNER BAG -Cajon-



TCB01BE

Beige

330 (L) x 310 (W) x 520 (H) mm
(13" x 12 1/4" x 20 1/2")

-Backpack straps

30.000,00

POWERPAD® DESIGNER BAG -Cajon-



TCB01MG

Moss Green

330 (L) x 310 (W) x 520 (H) mm
(13" x 12 1/4" x 20 1/2")

-Backpack straps

30.000,00

POWERPAD® DESIGNER BAG -Cajon-



TCB01NB

Navy Blue

330 (L) x 310 (W) x 520 (H) mm
(13" x 12 1/4" x 20 1/2")

-Backpack straps

30.000,00

POWERPAD® DESIGNER BAG -Cajon-



TCB01WR

Wine Red

330 (L) x 310 (W) x 520 (H) mm
(13" x 12 1/4" x 20 1/2")

-Backpack straps

30.000,00

POWERPAD® DESIGNER BAG -Twin Pedal-



TPB200BK

Black

450 (L) x 200 (W) x 300 (H) mm
(17 3/4" x 7 7/8" x 11 3/4")

-Accommodate both single and double pedals
-Removable storage case for using as single pedal case

26.900,00

POWERPAD® DESIGNER BAG -Twin Pedal-



TPB200BE

Beige

450 (L) x 200 (W) x 300 (H) mm
(17 3/4" x 7 7/8" x 11 3/4")

-Accommodate both single and double pedals
-Removable storage case for using as single pedal case

26.900,00

POWERPAD® DESIGNER BAG -Twin Pedal-



TPB200MG

Moss Green

450 (L) x 200 (W) x 300 (H) mm
(17 3/4" x 7 7/8" x 11 3/4")

-Accommodate both single and double pedals
-Removable storage case for using as single pedal case

26.900,00

POWERPAD® DESIGNER BAG -Twin Pedal-



TPB200NB

Navy Blue

450 (L) x 200 (W) x 300 (H) mm
(17 3/4" x 7 7/8" x 11 3/4")

-Accommodate both single and double pedals
-Removable storage case for using as single pedal case

26.900,00

POWERPAD® DESIGNER BAG -Twin Pedal-



TPB200WR

Wine Red

450 (L) x 200 (W) x 300 (H) mm
(17 3/4" x 7 7/8" x 11 3/4")

-Accommodate both single and double pedals
-Removable storage case for using as single pedal case

26.900,00

POWERPAD® DESIGNER BAG -Stick-



TSB24BK

Black

-Main pockets for 12 pairs of sticks, and side pockets for accessories
-Built-in hooks easily attach to floor tom
-Shoulder strap for portability
-Convenient inner pockets
-Size: 460mm x 180mm
-Side Pocket: 260mm x 160mm

11.900,00

POWERPAD® DESIGNER BAG -Stick-



TSB24BE

Beige

- Main pockets for 12 pairs of sticks, and side pockets for accessories
- Built-in hooks easily attach to floor tom
- Shoulder strap for portability
- Convenient inner pockets
- Size: 460mm x 180mm
- Side Pocket: 260mm x 160mm

11.900,00

POWERPAD® DESIGNER BAG -Stick-



TSB24MG

Moss Green

- Main pockets for 12 pairs of sticks, and side pockets for accessories
- Built-in hooks easily attach to floor tom
- Shoulder strap for portability
- Convenient inner pockets
- Size: 460mm x 180mm
- Side Pocket: 260mm x 160mm

11.900,00

POWERPAD® DESIGNER BAG -Stick-



TSB24NB

Navy Blue

- Main pockets for 12 pairs of sticks, and side pockets for accessories
- Built-in hooks easily attach to floor tom
- Shoulder strap for portability
- Convenient inner pockets
- Size: 460mm x 180mm
- Side Pocket: 260mm x 160mm

11.900,00

POWERPAD® DESIGNER BAG -Stick-



TSB24WR

Wine Red

- Main pockets for 12 pairs of sticks, and side pockets for accessories
- Built-in hooks easily attach to floor tom
- Shoulder strap for portability
- Convenient inner pockets
- Size: 460mm x 180mm
- Side Pocket: 260mm x 160mm

11.900,00

POWERPAD® DESIGNER BAG -Stick-



TSB12BK

Black

Stores about 6 pairs of sticks

- Top of the bag open to take out stick easily
- Elastic band easily attach to floor tom
- Convenient inner pockets

7.280,00

POWERPAD® DESIGNER BAG -Stick-



TSB12BE

Beige

Stores about 6 pairs of sticks

- Top of the bag open to take out stick easily
- Elastic band easily attach to floor tom
- Convenient inner pockets

7.280,00

POWERPAD® DESIGNER BAG -Stick-



TSB12MG

Moss Green

Stores about 6 pairs of sticks

- Top of the bag open to take out stick easily
- Elastic band easily attach to floor tom
- Convenient inner pockets

7.280,00

POWERPAD® DESIGNER BAG -Stick-



TSB12NB

Navy Blue

Stores about 6 pairs of sticks

- Top of the bag open to take out stick easily
- Elastic band easily attach to floor tom
- Convenient inner pockets

7.280,00

POWERPAD® DESIGNER BAG -Stick-



TSB12WR

Wine Red

Stores about 6 pairs of sticks

- Top of the bag open to take out stick easily
- Elastic band easily attach to floor tom
- Convenient inner pockets

7.280,00

POWERPAD® DESIGNER BAG -Stick-



TSB12DBK

Black Denim

Stores about 6 pairs of sticks

- Top of the bag open to take out stick easily
- Elastic band easily attach to floor tom
- Convenient inner pockets

7.280,00

POWERPAD® DESIGNER BAG -Stick-



TSB12DBL

Blue Denim
Stores about 6 pairs of sticks

- Top of the bag open to take out stick easily
- Elastic band easily attach to floor tom
- Convenient inner pockets

7.280,00

STANDARD SERIES DRUM BAG SET



DSS52K

22"x18"BD
10"x8"TT
12"x9"TT
16"x16"FT
14"x6.5"SD

- 600 denier high density water resister surface
- Water resistant nylon with 10mm thick cushion
- Ergonomic rubber handles

94.000,00

STANDARD SERIES DRUM BAG SET



DSS50S

20"x18"BD
10"x8"TT
12"x9"TT
14"x14"FT
14"x6.5"SD

- 600 denier high density water resister surface
- Water resistant nylon with 10mm thick cushion
- Ergonomic rubber handles

94.000,00

STANDARD SERIES DRUM BAG SET



DSS62S

22"x18"BD
10"x8"TT
12"x9"TT
14"x14"FT
16"x16"FT
14"x6.5"SD

- 600 denier high density water resister surface
- Water resistant nylon with 10mm thick cushion
- Ergonomic rubber handles

107.000,00

STANDARD SERIES DRUM BAG SET



DSS48LJ

(for Club-JAM kit)
18"x12" BD
10"x8" TT
14"x7" FT & 13"x5" SD (1bag)

- 600 denier high density water resister surface
- Water resistant nylon with 10mm thick cushion
- Ergonomic rubber handles

49.000,00

STANDARD SERIES DRUM BAG SET



DSS28LJ

(for Club-JAM MINI kit)
18"x12" BD
12"x5" SD

- 600 denier high density water resister surface
- Water resistant nylon with 10mm thick cushion
- Ergonomic rubber handles

35.400,00

STANDARD SERIES DRUM BAG SET



DSS36LJ

(for Club-JAM Suitcase kit)
16"x15" BD
10"x7" TT
12"x6" FT

- 600 denier high density water resister surface
- Water resistant nylon with 10mm thick cushion
- Ergonomic rubber handles

43.000,00

STANDARD SERIES DRUM BAG SET



DSS44LJ

(for Club-JAM Flyer kit)
14"x10" BD
10"x9" FT & 8"x6" TT (1bag)
10"x5" SD bag

- 600 denier high density water resister surface
- Water resistant nylon with 10mm thick cushion
- Ergonomic rubber handles

49.000,00

STANDARD SERIES DRUM BAG SET



DSS48LJP

(for Club-JAM Pancake kit)
18"x4" BD
10"x3.5" TT
13"x3.5" FT
12"x4" SD

- 600 denier high density water resister surface
- Water resistant nylon with 10mm thick cushion
- Ergonomic rubber handles

45.000,00

STANDARD SERIES DRUM BAG SET



DSS48S

18"x14" BD
12"x9" TT
14"x14" FT
14"x6.5" SD

- 600 denier high density water resister surface
- Water resistant nylon with 10mm thick cushion
- Ergonomic rubber handles

81.000,00

STANDARD SERIES DRUM BAG SET



DSS72S

22"x18" BD
8"x7" TT
10"x8" TT
12"x9" TT
14"x14" FT
16"x16" FT
14"x6.5" SD

-600 denier high density water resister surface
-Water resistant nylon with 10mm thick cushion
-Ergonomic rubber handles

116.000,00

STANDARD SERIES SNARE BAG



SBS14

14"x6.5" Snare Drum

-600 denier high density water resister surface
-Water resistant nylon with 10mm thick cushion
-Ergonomic rubber handles
-Carrying strap with shoulder pads

13.500,00

STANDARD SERIES HARDWARE BAG



SBH01

(for Compact / Lightweight Hardware)
670 (L) x180 (W) x190 (H) mm

-600 denier high density water resister surface
-Water resistant nylon with 10mm thick cushion
-Carrying strap with shoulder pads

17.700,00

STANDARD SERIES MICROPHONE STAND BAG



SBM01

Stores up to 6 pcs of Microphone Stands or 2pcs of Speaker Stands
1200 (L) x 220 (W) x 200 (H) mm

-600 denier high density water resister surface
-Water resistant nylon with 10mm thick cushion
-Carrying strap with shoulder pad

27.000,00

ACCESSORIES

We offer many unique accessories to enhance your playing, set up, and tone of the drums.

ACCESSORY TRAY



TAT10

- Tray size (inside dimension): 235mm x 254mm (9 1/4" x 10")
- Drink holder: up to diameter 90mm (3 1/2")
- Includes MC61 FastClamp for connecting stands with pipes from 15.9mm to 28.6mm in diameter.
- Includes 2- S-Hooks for hanging bags
- Rims can hold up to 16mm (0.63") diameter drum sticks
- Mounted 5/8" nut for straight mic stand on bottom of the tray
- Weight capacity: 2.5kg (5.5lbs)

26.600,00

DRUM STICK HOLDER



STH10

The STH10 Stick Holder is designed to hold spare sticks and can be attached to hardware anywhere on the drum kit.

-Size: 280mm(L) x 60mm(W) x 90mm(H)
(11 1/32" x 2 11/32" x 3 17/32")
-Storing 2 pairs of drumsticks
-The attachment for connecting stands with pipes from 15.9mm to 28.6mm in diameter.

4.580,00

RHYTHM WATCH



RW200

Tempo Range: 30-250 BPM
Tempo, Beat & Sound Memory: 30 Songs
Beats: 0-9
Display: LCD with BACK LIGHT
Size: 127 x 35 x 150mm (5" x 1.4" x 6")
Weight: 285g including battery
Power Supply: 9V Battery (S-006P) or DC9V 200mA adapter

38.100,00

RHYTHM WATCH MINI



RW30

Tempo Range: 30-250 BPM
Beats: 0-9
Display: LCD display with BACK LIGHT
Size: 61 x 25 x 118mm (2 1/2" x 1" x 4 5/8")
Weight: 90g including battery
Power Supply: 2 x AAA Batteries (3V)

14.200,00

RHYTHM WATCH HOLDER



RWH10
for RW200
7.280,00

TENSION WATCH



TW200
The TW200 TAMA Tension Watch is very compact and is equipped with an easy to read dial. It comes with a detachable nylon bumper to ensure consistent measuring distance from the hoop, resulting in an evenly tensioned drum for the best sound.
50.000,00

TENSION WATCH



TW100
The TW100 measures actual head tension and features an easy-to-read meter, so you can record the numbers and duplicate your best tuning time after time. You can also use the sample tunings suggested in the directions.
46.000,00

DRUMMER'S GLOVE



TDG10BKL
Drummer's Glove with featuring extra soft and durable synthetic leather which prevents any slipping while playing even with wet condition caused by sweating.
Black
TDG10BKM (Medium)
TDG10BKL (Large)
TDG10BKLX (Extra Large)
13.400,00

GRIP WRAP



TGW10BK MADE IN JAPAN
(2prs / set)
TAMA's Grip Wrap is designed to provide the player with a comfortable, non-slip surface for their drumsticks.
-Non-Slip Surface
-Soft and Comfortable Feel
-Highly Durable Material Made in Japan
3.810,00

WOOD HOOP PROTECTOR



WHP2
(2pcs / set)
Special adhesive pieces protect your wood hoop from being scratched by preventing the bass drum pedal from twisting or slipping.
1.890,00

MULTI TOOL



TMT9
Quick access multi tool for drums
-Hex Wrench 5.0mm/4.0mm/3.0mm/2.5mm/
2.0mm, Keychain Link, Hex Nut Driver, Phillips
Screwdriver, Drum Keys (x2)
8.050,00

DRUM RUG -TAMA Logo Pattern-



TDR-TL
2,000mm x 1,800mm
(78 3/4" x 70 7/8")
-Non-slip design helps keep drums & hardware in place
-Extra-large size accommodates most drum setups
-Hook and loop fasteners for easy transport
63.000,00

DRUM RUG -TAMA Logo Pattern / Small-



TDRS-TL
1,680mm x 1,330mm
(66 1/8" x 52 3/8")
-Non-slip design helps keep drums & hardware in place
-Fits to accommodate compact drum set
-Hook and loop fasteners for easy transport
38.100,00

DRUM RUG -Oriental Pattern-



TDR-OR
2,000mm x 1,800mm
(78 3/4" x 70 7/8")
-Non-slip design helps keep drums & hardware in place
-Extra-large size accommodates most drum setups
-Hook and loop fasteners for easy transport
63.000,00

DRUM RUG -Southwestern Pattern-



TDR-SW

2,000mm x 1,800mm
(78 3/4" x 70 7/8")

- Non-slip design helps keep drums & hardware in place
- Extra-large size accommodates most drum setups
- Hook and loop fasteners for easy transport

63.000,00

DRUM RUG -Paisley Pattern-



TDR-PA

2,000mm x 1,800mm
(78 3/4" x 70 7/8")

- Non-slip design helps keep drums & hardware in place
- Extra-large size accommodates most drum setups
- Hook and loop fasteners for easy transport

63.000,00

REMO® FIBERSKYN POWERSTROKE 3 DIPLOMAT



RFxxBMST

(TAMA Logo)

RF18BMST (18")	22.700,00
RF20BMST (20")	24.600,00
RF22BMST (22")	26.900,00
RF24BMST (24")	29.200,00

WHITE COATED HEADS



CTxxBMOT

(TAMA & Starclassic Logo)

CT18BMOT (18")	14.600,00
CT20BMOT (20")	16.900,00
CT22BMOT (22")	17.700,00
CT24BMOT (24")	19.600,00
CT26BMOT (26")	21.900,00

FIBER LAMINATED HEADS



FBxxBMFS

(TAMA & Starclassic Logo)

FB20BMFS (20")	18.100,00
FB22BMFS (22")	19.300,00
FB24BMFS (24")	21.200,00

BLACK HEADS



BKxxBMTT

(TAMA & Starclassic Logo)

BK20BMTT (20")	18.100,00
BK22BMTT (22")	19.300,00
BK24BMTT (24")	21.200,00

SMOOTH WHITE HEADS



SWxxBMTT

(TAMA & Starclassic Logo)

SW20BMTT (20")	18.100,00
SW22BMTT (22")	19.300,00
SW24BMTT (24")	21.200,00

FIBER LAMINATED HEADS -BLACK-



BKxxBMFH

(TAMA Logo for Superstar Hyper-Drive)

BK22BMFH (22")	19.300,00
BK24BMFH (24")	21.200,00

WHITE COATED HEADS -TAMA LOGO-



CTxxBMSV

(TAMA Logo)

CT18BMSV (18")	15.800,00
CT20BMSV (20")	18.100,00
CT22BMSV (22")	19.300,00

BLACK HEADS -TAMA LOGO-



BKxxBMWS

(TAMA Logo)

BK20BMWS (20")	18.100,00
BK22BMWS (22")	19.300,00
BK24BMWS (24")	21.200,00

DRUM KEY



TDK10

Chrome

2.190,00

DRUM KEY



TDK10BN

Black Nickel

2.580,00

DRUM KEY



TDK05

1.310,00

TENSION LOCK



TTL10

(10pcs/set)

The Tension Lock prevents tension bolts from loosening while playing by simply set it on the tension bolt head. You can tune the drum without having to detach the Tension Lock, thanks to an elastic O-ring around its hole.

4.390,00

DIE-CAST HOOPS



MDH14

TAMA's die-cast hoops deliver an incredibly sharp, solid rim shot that cannot be found in any other hoop.

MDH14-8 (14" 8 hole batter side) **38.100,00**

MDH14S-8 (14" 8 hole snare side) **38.100,00**

MDH14-10 (14" 10 hole batter side) **38.100,00**

MDH14S-10 (14" 10 hole snare side) **38.100,00**

2.3mm BRASS MIGHTY HOOPS



MFB14

Brass Mighty Hoop provides a warm and open sound with mild attack and long sustain.

MFB14-10N (14" 10 hole batter side) **52.000,00**

MFB14S-10N (14" 10 hole snare side) **52.000,00**

2.3mm STEEL MIGHTY HOOPS



MFM14

Steel Mighty Hoop provides a bright and open sound.

MFM14-8 (14" 8 hole batter side) **23.100,00**

MFM14S-8 (14" 8 hole snare side) **23.100,00**

MFM14-10 (14" 10 hole batter side) **23.100,00**

MFM14S-10 (14" 10 hole snare side) **23.100,00**

3.0mm ULTIMATE STEEL MIGHTY HOOPS



MUS14

3.0mm thick Ultimate Steel Mighty Hoop provides extra power and volume.

MUS1410 (14" 10 hole batter side) **26.600,00**

MUS14S10 (14" 10 hole snare side) **26.600,00**

2.3mm SOUND ARC HOOPS



MSH14

Steel Sound Arc Hoop enhances the natural tone of the snare drum and offers sensitivity, precise tuning, and control.

MSH1410 (14" 10 hole batter side) **18.900,00**

MSH14S10 (14" 10 hole snare side) **18.900,00**

2.3mm BRASS SOUND ARC HOOPS



MSB14

Brass Sound Arc Hoop provides an open sound with rich harmonic overtones, made of brass with an inward curved shape.

MSB148D (14" 8 hole batter side) **38.100,00**

MSB14S8D (14" 8 hole snare side) **38.100,00**

CUSTOMIZED BRASS MIGHTY HOOPS



MSP14

Customized Brass Mighty Hoop provides a sharper and brighter attack with rich harmonic overtones, made of brass with a slightly shaved down edge.

MSP14-8
(14" 8 hole batter side) **39.600,00**

MSP14S-8
(14" 8 hole snare side) **46.000,00**

MAPLE WOOD HOOPS

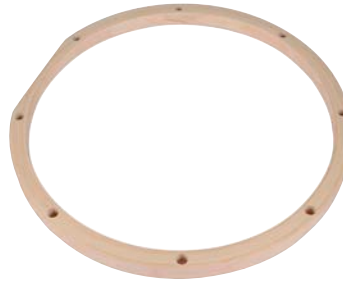

WMH14

Wood Hoop provides a warm, woody sound with soft attack. Can be mounted on a standard 14" snare drum stand.

WMH1408B
(14" 8 hole batter side) **46.000,00**

WMH1408S
(14" 8 hole snare side) **46.000,00**

WMH1410B
(14" 10 hole batter side) **46.000,00**

WMH1410S
(14" 10 hole snare side) **46.000,00**

SUPER SENSITIVE HI-CARBON SNARE WIRES

MS20RL

Super Sensitive Hi-Carbon Snare Wire fits more closely to the snare side head, providing greater sensitivity and brighter, crisper sound.



MS20RL13C
(13" 20 strands Hi-Carbon Steel) **9.590,00**

MS20RL14C
(14" 20 strands Hi-Carbon Steel) **9.590,00**

SUPER SENSITIVE HI-CARBON SNARE WIRE FOR CONCERT

MS20L14C8

A thin brass plate and softer hi-carbon coils respond to even the softest touch on the edge of the batter head.



9.590,00

STAINLESS STEEL STRAIGHT SNARE WIRE

MS20M14ST

20 strands steel straight wire for concert. Extra short sustain, dark and crisp.



MS20M14ST (14" 20 strands Steel)

19.600,00

STARCLASSIC SNARE WIRES -CARBON STEEL-

MS20SNxxS

MS20SN10S
(10" 20 strands Carbon Steel) **6.120,00**

MS20SN12S
(12" 20 strands Carbon Steel) **6.120,00**

MS20SN13S
(13" 20 strands Carbon Steel) **6.120,00**

MS20SN14S
(14" 20 strands Carbon Steel) **6.120,00**



STARCLASSIC SNARE WIRES -BELL BRASS-

MS20SN14B

The MS20SN14B features bell brass strands for greater sensitivity.



MS20SN14B (14" 20 strands Bell Brass)

9.590,00

STARCLASSIC SNARE WIRES -HI-CARBON STEEL-

MS20SNxxC

MS20SN13C
(13" 20 strands Hi-Carbon Steel) **9.590,00**

MS20SN14C
(14" 20 strands Hi-Carbon Steel) **9.590,00**



REGULAR SNARE WIRES -CARBON STEEL-

MS12R14S

(14" 12-strand Carbon Steel)

4.970,00



REGULAR SNARE WIRES -CARBON STEEL-

MS20R14S

(14" 20-strand Carbon Steel)

5.350,00



REGULAR SNARE WIRES -CARBON STEEL-

MS30R14S

(14" 30-strand Carbon Steel)

8.820,00



REGULAR SNARE WIRES -CARBON STEEL-

MS42R14S

(14" 42-strand Carbon Steel)

9.200,00



REGULAR SNARE WIRES -HI-CARBON STEEL-

MS42R14C

(14" 42-strand Hi-Carbon Steel)

10.400,00



HOLD TIGHT™ WASHERS

SRW620P

(20pcs/set)

The rubber rings inside of the cup-shaped stainless steel washers absorb impact vibrations and keep the hoop and tension bolts in constant contact to prevent from loosening of tension.

6.510,00



PLASTIC WASHERS

PW620

(20pcs/set)

2.5mm thick nylon washers decrease noise and make tuning easier and more stable.

2.270,00



METAL WASHERS

MW620

(20pcs/set)

Standard metal tension bolt washers.

2.270,00



SNARE WIRE STRAPS

MST20

(2pcs/set)

These flexible yet durable 15mm wide nylon snare wire straps are featured on most of TAMA snare drums.

1.890,00



SNARE WIRE STRINGS

SPC50P4

(2prs/pack)

The amazingly durable and flexible snare wire string is made of Dupont Kevlar® cable wrapped in polyester fiber for an even higher tensile strength than steel wire. (Kevlar® is a registered trademark of Dupont® Corporation.)

2.850,00



DYNA BEATER

BDY30FB

Featuring black felt and a slightly tapered shape, this traditional style beater provides impact to the bass drum head surface evenly to maximize clear, dynamic articulation.

13.100,00



POWER-STRIKE COBRA BEATER

CB900PS

Felt

11.500,00



ACCU-STRIKE COBRA BEATER



CB900AS

Rubber

11.500,00

COBRA BEATER -Felt-



CB90F

Felt

10.700,00

COBRA BEATER -Rubber-



CB90R

Rubber

10.700,00

COBRA BEATER -Wood-



CB90W

Wood

10.700,00

POWER-STRIKE COBRA BEATER HEAD



CB900PSH

Felt

9.590,00

ACCU-STRIKE COBRA BEATER HEAD



CB900ASH

Rubber

9.590,00

COBRA BEATER HEAD -Felt-



CB90FH

Felt

7.660,00

COBRA BEATER HEAD -Rubber-



CB90RH

Rubber

7.660,00

COBRA BEATER HEAD -Wood-



CB90WH

Wood

7.660,00

DUAL SIDED BEATER -Felt-



DS30

Felt

9.590,00

DUAL SIDED BEATER -Felt-



DS30G
Felt
9.590,00

DUAL SIDED BEATER -Rubber-



DS30R
Rubber
9.590,00

THE CLASSIC BEATER -Felt-



CLB30F
Felt
8.820,00

TRADITIONAL BEATER -Felt-



TTB30F
Felt
10.700,00

TRADITIONAL BEATER -Wood-



TTB30W
Wood
10.700,00

TOE STOPPER



HP900-81
1.890,00

BEATER BALANCER



BC7
1.890,00

TIGHT LOCK



TLK5
1.890,00

SPRING FOR SPEED COBRA



HP910-7S
1.890,00

SPRING -Regular-



HP900-7R
1.890,00

SPRING -Heavy-



HP900-7H

1.890,00

COBRA COIL



CC900S

The Cobra Coil is a steel spring which assists in the return of the footboard to its original position. It be adjusted to different positions, forward or backward, on the base plate.

11.500,00

DRUM HAMMER



DH7

3.810,00

TWIN PEDAL ATTACHMENT



TPA90

Specially designed attachment to connect Speed Cobra and Iron Cobra 900 series pedals with Speed Cobra and Iron Cobra 900 series Hi-hat stands.

5.740,00

DYNA-SYNC PEDAL CASE -SINGLE-



PCDS1

PCDS1 (for Dyna-Sync Single Pedal)

28.100,00

DYNA-SYNC PEDAL CASE -TWIN-



PCDS1TW

PCDS1TW (for Dyna-Sync Twin Pedal)

38.500,00

IRON COBRA PEDAL CASE -SINGLE-



PC900S

PC900S (for Iron Cobra Single Pedal)

28.100,00

IRON COBRA PEDAL CASE -TWIN-



PC900TW

PC900TW (for Iron Cobra Twin Pedal)

38.500,00

SPEED COBRA PEDAL CASE -SINGLE-



PC910S

PC910S (for Speed Cobra Single Pedal)

28.100,00

SPEED COBRA PEDAL CASE -TWIN-



PC910TW

PC910TW (for Speed Cobra Twin Pedal)

38.500,00

1ST CHAIR ROUND RIDER XL SEAT -Cloth Top-



HTS8BC

You can improve your existing throne with the firm support and comfort of 1st Chair seats.

59.000,00

1ST CHAIR ROUND RIDER XL SEAT



HTS8B

You can improve your existing throne with the firm support and comfort of 1st Chair seats.

59.000,00

1ST CHAIR ROUND RIDER XL SEAT -Red-



HTS8R

You can improve your existing throne with the firm support and comfort of 1st Chair seats.

59.000,00

1ST CHAIR ERGO-RIDER SEAT -Cloth Top-



HTS7BC

You can improve your existing throne with the firm support and comfort of 1st Chair seats.

59.000,00

1ST CHAIR ERGO-RIDER SEAT



HTS7B

You can improve your existing throne with the firm support and comfort of 1st Chair seats.

59.000,00

1ST CHAIR GLIDE RIDER SEAT -Cloth Top-



HTS5BCN

You can improve your existing throne with the firm support and comfort of 1st Chair seats.

59.000,00

1ST CHAIR WIDE RIDER SEAT -Cloth Top-



HTS5BC

You can improve your existing throne with the firm support and comfort of 1st Chair seats.

59.000,00

1ST CHAIR WIDE RIDER SEAT



HTS5B

You can improve your existing throne with the firm support and comfort of 1st Chair seats.

59.000,00

1ST CHAIR ROUND RIDER SEAT -Cloth Top-



HTS4BC

You can improve your existing throne with the firm support and comfort of 1st Chair seats.

44.000,00

1ST CHAIR ROUND RIDER SEAT



HTS4B

You can improve your existing throne with the firm support and comfort of 1st Chair seats.

44.000,00

1ST CHAIR THRONE BASE -HYDRAULIX-



HSB5N

*Seat holder included.

You can improve your existing throne or seat by changing the legs to one of the 1st Chair individual throne bases. The Hydraulix throne base comes with a seat holder with an adjustment lever.

88.000,00

1ST CHAIR THRONE BASE -Quartet-



HSB4N

You can improve your existing throne or seat by changing the legs to one of the 1st Chair individual throne bases. (diameter of upper rods: 22.2mm).

80.000,00

1ST CHAIR THRONE BASE -Trio-



HSB3N

You can improve your existing throne or seat by changing the legs to one of the 1st Chair individual throne bases. (diameter of upper rods: 22.2mm).

72.000,00

1ST CHAIR THRONE BASE -Trio-



HSB3

for Round Rider Series

You can improve your existing throne or seat by changing the legs to one of the 1st Chair individual throne bases. (diameter of upper rods: 22.2mm).

63.000,00

1ST CHAIR BACKREST ATTACHMENT



HTB5B

for any 1st Chair thrones

Sitting on a throne for a long period of time is tough on your back. The HTB5B can be adjusted up and down AND forward AND it can be detached from the seat when the gig is done. Slick!

50.000,00

TAMA LOGO STICKER -White-



TLSxxWH

TLS120WH 60mm x 280mm

1.810,00

TLS100WH 50mm x 230mm

1.690,00

TLS80WH 40mm x 190mm

1.690,00

TLS70WH 35mm x 150mm

1.690,00

TAMA LOGO STICKER -Black-



TLSxxBK

TLS120BK 60mm x 280mm

1.810,00

TLS100BK 50mm x 230mm

1.690,00

TLS80BK 40mm x 190mm

1.690,00

TLS70BK 35mm x 150mm

1.690,00

MEMORY LOCK



ML11

for 10.5mm diameter L-rod

3.810,00

MEMORY LOCK



ML12

for 10.5-12mm diameter boom arm

3.810,00

MEMORY LOCK



ML191C

for 19.1mm diameter pipe

5.080,00

MEMORY LOCK



ML191N
for 19.1mm diameter pipe
2.960,00

MEMORY LOCK



ML222C
for 22.2mm diameter pipe
5.080,00

MEMORY LOCK



ML222NT
for 22.2mm diameter pipe
2.960,00

MEMORY LOCK



ML254TC
for 25.4mm diameter pipe
2.960,00

MEMORY LOCK



ML254C
for 25.4mm diameter pipe
5.080,00

MEMORY LOCK



ML28C
for 28.6mm diameter pipe
6.310,00

QUICK-SET CYMBAL MATE



QC8
(M8)
2.270,00

QUICK-SET CYMBAL MATE (4pcs/set)



QC8-B4
(M8: 4pcs/pack)
6.810,00

CYMBAL MATE



CM8P
(M8: 2pcs/pack)
1.350,00

RING-TRUE FELT for STAR HARDWARE



RTF35P
(2pcs/pack)
4.770,00

FELT WASHER



7081P

(2pcs/pack)

1.350,00

REVERSIBLE CYMBAL BOTTOM



RB8P

(M8: 2pcs/pack)

1.350,00

STAR HARDWARE CYMBAL BOTTOM



CB8P

(M8: 2pcs/pack)

2.660,00

STAR HARDWARE CYMBAL PROTECTION SLEEVE



CPS8P

(M8: 2pcs/pack)

3.040,00

HAT STACK



CSH5

- Easily attach a small cymbal to hi-hat rod measuring up to 7mm in diameter
- Compact size and lightweight for easy transport and storage - 25mm (1") diameter x 40mm (1.5") height
- Ability to adjust cymbal sustain

5.740,00

SIZZLE TOUCH DROP CLUTCH



STDC7

TAMA's Sizzle Touch Drop Clutch allows you to adjust the gap between the top and bottom cymbals, allowing for fine adjustments to achieve the desired open sound.

22.300,00

QUICK-SET HI-HAT CLUTCH



QHC7

With just one touch, the Quick-Set Clutch can be attached or removed - simply push the button on the side of the clutch.
(Fits 7mm or smaller diameter pull rod)

13.400,00

SWING LOCK CLUTCH



SLC08

This allows the top hi-hat cymbal to float more freely, maximizing the natural resonance of the cymbals.
(Fits 6.3mm diameter pull rod)

11.500,00

SECURITY CLUTCH



CL08

Having your hi-hat clutch come loose is now a thing of the past with TAMA's Security Clutch. When the T-bolt is tightened, bottom lock nut and top section press on the rod for complete security.
(Fits 6.3mm diameter pull rod)

6.620,00

HI-HAT TENSION RODS



HH905-3/HH905D3S

Tension Rod w/ Plastic Nut (M6)

HH905-3 (Long / 500mm (19 11/16"))

2.350,00

HH905D3S (Short / 350mm (13 3/4"))

2.350,00

REMOTE HI-HAT STAND CABLE

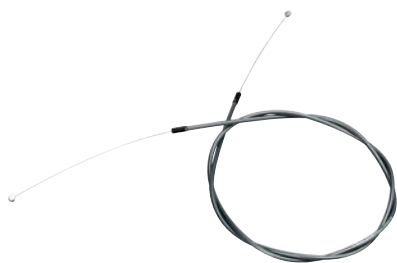

HH905RH2L/HH905RH2S

Exchangeable Cable for HH905RH

HH905RH2L (Long / 2,300mm (90 1/2"))
21.100,00

HH905RH2S (Short / 1,200mm (47 1/4"))
17.300,00

HI-HAT CLUTCH FELT WASHERS



CL08-13P

(2pcs/pack)

1.690,00

QUICK-LOCK TOM BRACKET



MQMP-TCH

(for tom tom/Chrome)

-Quick and easy setup in position
-Enhanced resonance with rubber lining

17.300,00

QUICK-LOCK TOM BRACKET



MQMP-TBN

(for tom tom/Black Nickel)

-Quick and easy setup in position
-Enhanced resonance with rubber lining

17.300,00

QUICK-LOCK TOM BRACKET



MQMP-FCH

(for floor tom/Chrome)

-Quick and easy setup in position
-Enhanced resonance with rubber lining

14.600,00

QUICK-LOCK TOM BRACKET



MQMP-FBN

(for floor tom/Black Nickel)

-Quick and easy setup in position
-Enhanced resonance with rubber lining

14.600,00

SOUND FOCUS PAD -for Cocktail-JAM-



SFP530

Bass Drum Mute for Cocktail-JAM kits

12.300,00

TAMA LOGO T-SHIRT BLACK



TAMT004

Available size: S/M/L/XL/XXL

TAMT004S
TAMT004M
TAMT004L
TAMT004XL
TAMT004XXL

9.590,00

TAMA "T" LOGO T-SHIRT BLACK



TAMT006

Available size: S/M/XL/XXL

TAMT006S
TAMT006M
TAMT006XL
TAMT006XXL

7.660,00

TAMA BLACKLOGO T-SHIRT BLACK



TAMT007

Available size: M/L/XL/XXL

TAMT007M
TAMT007L
TAMT007XL
TAMT007XXL

9.590,00

TAMA "T" LOGO LONG SLEEVED T-SHIRT BLACK



TAML001

Available size: S/M/L/XL/XXL

TAML001S
TAML001M
TAML001L
TAML001XL
TAML001XXL

11.500,00

TAMA LOGO PULLOVER HOODIE



TAMP001

Available size: S/M/L/XL/XXL

TAMP001S
TAMP001M
TAMP001L
TAMP001XL
TAMP001XXL

20.400,00

TAMA WATER BOTTLE



TAMB001

Capacity: 500ml / 16.9oz
-Materials: Tritan (Bottle) / Polypropylene (Lid)
- Upper temperature tolerance: 100°C / 212°F
- Lower temperature tolerance: -10°C / 14°F
- BPA Free

7.660,00

TAMA MUG



TAMM002

-Size: 72mm (D) x 90mm (H)
(2 3/4" x 3 1/2")

-Material: Stoneware

5.780,00

TAMA LOGO LANYARD



TNKS001

-Length: 500 mm
-Width: 15 mm
-Safety breakaway release
-Material: Polyester

3.430,00

TAMA LOGO TOWEL BLACK



TTWL001

MADE IN JAPAN

-Length: 200 mm
-Width: 1,100 mm
-Material: Cotton

7.660,00

TAMA LOGO PIN



TMPIN001

NEW

-Length: 10.5 mm
-Width: 38 mm
-Height: 10mm
-Material: Nickel Plated Brass

2.270,00

DRUM STICKS

TAMA drum sticks are molded under strict quality control standards from carefully selected wood materials and are renowned for their consistent high quality.

ORIGINAL SERIES STICK -Japanese Oak-

0213-B

MADE IN JAPAN

Diameter: 13mm (0.510")
Length: 406mm (16")
Tip Style: Ball



4.580,00

ORIGINAL SERIES STICK -Japanese Oak-

0214-B

MADE IN JAPAN

Diameter: 14mm (0.550")
Length: 406mm (16")
Tip Style: Ball



4.580,00

ORIGINAL SERIES STICK -Japanese Oak-

0215-B

MADE IN JAPAN

Diameter: 15mm (0.590")
Length: 406mm (16")
Tip Style: Ball



4.580,00

ORIGINAL SERIES STICK -Japanese Oak-

0216-B

MADE IN JAPAN

Diameter: 16mm (0.630")
Length: 406mm (16")
Tip Style: Ball



4.580,00

ORIGINAL SERIES STICK -Japanese Oak-

0213-P

MADE IN JAPAN

Diameter: 13mm (0.510")
Length: 406mm (16")
Tip Style: Popular



4.580,00

ORIGINAL SERIES STICK -Japanese Oak-

0214-P

MADE IN JAPAN

Diameter: 14mm (0.550")
Length: 406mm (16")
Tip Style: Popular



4.580,00

ORIGINAL SERIES STICK -Japanese Oak-

0215-P

MADE IN JAPAN

Diameter: 15mm (0.590")
Length: 406mm (16")
Tip Style: Popular



4.580,00

ORIGINAL SERIES STICK -Japanese Oak-

0214-S

MADE IN JAPAN

Diameter: 14mm (0.550")
Length: 406mm (16")
Tip Style: Small



4.580,00

ORIGINAL SERIES STICK -Japanese Oak-

0215-S

MADE IN JAPAN

Diameter: 15mm (0.590")
Length: 406mm (16")
Tip Style: Small



4.580,00

TRADITIONAL SERIES STICK -Japanese Oak-

7A

MADE IN JAPAN

Diameter: 13mm (0.510")
Length: 390mm (15 3/8")
Tip Style: 7A



4.580,00

TRADITIONAL SERIES STICK -Japanese Oak-

7AN

MADE IN JAPAN

Diameter: 13mm (0.510")
Length: 390mm (15 3/8")
Tip Style: 7A (Nylon)



4.970,00

TRADITIONAL SERIES STICK -Japanese Oak-

5A

MADE IN JAPAN

Diameter: 14mm (0.550")
Length: 406mm (16")
Tip Style: 5A



4.580,00

TRADITIONAL SERIES STICK -Japanese Oak-

5AN

MADE IN JAPAN

Diameter: 14mm (0.550")
Length: 406mm (16")
Tip Style: 5A (Nylon)



4.970,00

TRADITIONAL SERIES STICK -Japanese Oak-

8A

MADE IN JAPAN

Diameter: 14mm (0.550")
Length: 406mm (16")
Tip Style: 8A



4.580,00

TRADITIONAL SERIES STICK -Japanese Oak-

5B

MADE IN JAPAN

Diameter: 15mm (0.590")
Length: 406mm (16")
Tip Style: 5B



4.580,00

TRADITIONAL SERIES STICK -Japanese Oak-

5BN

MADE IN JAPAN

Diameter: 15mm (0.590")
Length: 406mm (16")
Tip Style: 5B (Nylon)



4.970,00

TRADITIONAL SERIES STICK -American Hickory-

H7A

MADE IN JAPAN

Diameter: 13mm (0.510")
Length: 390mm (15 3/8")
Tip Style: 7A



4.970,00

TRADITIONAL SERIES STICK -American Hickory-

H5A

MADE IN JAPAN

Diameter: 14mm (0.550")
Length: 406mm (16")
Tip Style: 5A



4.970,00

TRADITIONAL SERIES STICK -American Hickory-

H8A

MADE IN JAPAN

Diameter: 14mm (0.550")
Length: 406mm (16")
Tip Style: 8A



4.970,00

TRADITIONAL SERIES STICK -American Hickory-

H5B

MADE IN JAPAN

Diameter: 15mm (0.590")
Length: 406mm (16")
Tip Style: 5B



4.970,00

OAK LAB SERIES -Smash-

OL-SM

MADE IN JAPAN

Weight and balance for huge power.

Diameter: 15mm (0.590")
Length: 419mm (16 1/2")
Tip Style: Acorn



4.580,00

OAK LAB SERIES -Resonator-

OL-RE

MADE IN JAPAN

Heavy for rich tones. Quick rebound.

Diameter: 15.25mm (0.600")
Length: 410mm (16 5/32")
Tip Style: Arrow



4.580,00

OAK LAB SERIES -Fast Blast-

OL-FA

MADE IN JAPAN

(Natural / Uncoated)
Modified 5A for more speed. Large tip and Oak enhances volume.

Diameter: 14mm (0.550")
Length: 406mm (16")
Tip Style: Large Ball



4.580,00

OAK LAB SERIES -Swingin'-

OL-SW

MADE IN JAPAN

Oak provides a bright cymbal tone and enhanced cross stick sound.

Diameter: 12.75mm (0.500")
Length: 403mm (15 7/8")
Tip Style: Oval



4.580,00

OAK LAB SERIES -Full Balance-

OL-FU

MADE IN JAPAN

Weighted for accuracy and control.

Diameter: 14.5mm (0.570")
Length: 406mm (16")
Tip Style: True Round



4.580,00

REDZONE -Japanese Oak-

5ARZ

MADE IN JAPAN

(Silver Logo)

Diameter: 14mm (0.550")
Length: 419mm (16 1/2")
Tip Style: 5A (Nylon)



4.970,00

REDZONE -Japanese Oak-

5BRZ

MADE IN JAPAN

(Silver Logo)

Diameter: 15mm (0.590")
Length: 419mm (16 1/2")
Tip Style: 5B (Nylon)



4.970,00

RHYTHMIC FIRE -Japanese Oak-

7A-F

MADE IN JAPAN

(Natural)

Diameter: 13mm (0.510")
Length: 390mm (15 3/8")
Tip Style: 7A



4.580,00

RHYTHMIC FIRE -Japanese Oak-

5A-F

(Natural)

MADE IN JAPAN

Diameter: 14mm (0.550")
Length: 406mm (16")
Tip Style: 5A



4.580,00

RHYTHMIC FIRE -Japanese Oak-

5B-F

(Natural)

MADE IN JAPAN

Diameter: 15mm (0.590")
Length: 406mm (16")
Tip Style: 5B



4.580,00

RHYTHMIC FIRE -Japanese Oak-

7A-F-BS

(Black, Silver Pattern)

MADE IN JAPAN

Diameter: 13mm (0.510")
Length: 390mm (15 3/8")
Tip Style: 7A



5.350,00

RHYTHMIC FIRE -Japanese Oak-

5A-F-BS

(Black, Silver Pattern)

MADE IN JAPAN

Diameter: 14mm (0.550")
Length: 406mm (16")
Tip Style: 5A



5.350,00

RHYTHMIC FIRE -Japanese Oak-

5B-F-BS

(Black, Silver Pattern)

MADE IN JAPAN

Diameter: 15mm (0.590")
Length: 406mm (16")
Tip Style: 5B



5.350,00

RHYTHMIC FIRE -Japanese Oak-

7A-F-BR

(Black, Red Pattern)

MADE IN JAPAN

Diameter: 13mm (0.510")
Length: 390mm (15 3/8")
Tip Style: 7A



5.350,00

RHYTHMIC FIRE -Japanese Oak-

5A-F-BR

(Black, Red Pattern)

MADE IN JAPAN

Diameter: 14mm (0.550")
Length: 406mm (16")
Tip Style: 5A



5.350,00

RHYTHMIC FIRE -Japanese Oak-

5B-F-BR

(Black, Red Pattern)

MADE IN JAPAN

Diameter: 15mm (0.590")
Length: 406mm (16")
Tip Style: 5B



5.350,00

STICKS OF DOOM -Japanese Oak-

7A-S

(Natural)

MADE IN JAPAN

Diameter: 13mm (0.510")
Length: 390mm (15 3/8")
Tip Style: 7A



4.580,00

STICKS OF DOOM -Japanese Oak-

5A-S

(Natural)

MADE IN JAPAN

Diameter: 14mm (0.550")
Length: 406mm (16")
Tip Style: 5A



4.580,00

STICKS OF DOOM -Japanese Oak-

5B-S

MADE IN JAPAN

(Natural)

Diameter: 15mm (0.590")
Length: 406mm (16")
Tip Style: 5B



4.580,00

STICKS OF DOOM -Japanese Oak-

7A-S-BS

MADE IN JAPAN

(Black, Silver Pattern)

Diameter: 13mm (0.510")
Length: 390mm (15 3/8")
Tip Style: 7A



5.350,00

STICKS OF DOOM -Japanese Oak-

5A-S-BS

MADE IN JAPAN

(Black, Silver Pattern)

Diameter: 14mm (0.550")
Length: 406mm (16")
Tip Style: 5A



5.350,00

STICKS OF DOOM -Japanese Oak-

5B-S-BS

MADE IN JAPAN

(Black, Silver Pattern)

Diameter: 15mm (0.590")
Length: 406mm (16")
Tip Style: 5B



5.350,00

SUEDE-GRIP DRUM STICKS -Japanese Oak-

5A-SG

MADE IN JAPAN

(SUEDE-GRIP Finish)

Diameter : 14mm (0.550")
Length : 406mm (16")
Tip Style : 5A



4.970,00

SUEDE-GRIP DRUM STICKS -Japanese Oak-

5B-SG

MADE IN JAPAN

(SUEDE-GRIP Finish)

Diameter : 15mm (0.590")
Length : 406mm (16")
Tip Style : 5B



4.970,00

DIRK VERBEUREN MODEL -Japanese Oak-

0-DVM2

NEW

MADE IN JAPAN

Dirk Verbeuren (MEGADETH)

Diameter: 16mm (0.630")
Length: 406mm (16")



4.200,00

MARIO DUPLANTIER MODEL -American Hickory-

H-MD

MADE IN JAPAN

Mario Duplantier (Gojira)

Diameter: 16.5mm (0.649")
Length: 432mm (17")



4.580,00

ALEX RÜDINGER MODEL -American Hickory-

H-RUDI

MADE IN JAPAN

Alex Rüdinger

Diameter: 16mm (0.630")
Length: 416mm (16 3/8")
Non-Slipping Lacquer Finish



5.740,00

ANUP SASTRY MODEL -American Hickory-

H-AS

MADE IN JAPAN

Anup Sastry

Diameter: 16mm (0.630")
Length: 432mm (17")



4.580,00

MARCHING PERCUSSION

After a long period of planning and experimentation, TAMA Marching Percussion is finally complete. High durability, various unique features for function and comfort, and revolutionary improvements allow total customized playability for everyone.

FIELDSTAR MARCHING SNARE DRUMS



Color: Deeper Purple (DPP)

MS1412L

- Shell Materials : Maple 6ply 5mm
- Number of Lugs : 12 lugs with aluminum tube pipes
- Weight :
 - MS1409 14" x 9" 12.9 lbs (5.9kg)
 - MS1412 14" x 12" 14.2 lbs (6.5kg)
- Strainer : Low Profile Strainer
- Snare Structure : Less stress with free floating and detachable gut frame
- Tension Rods and Washers : 6 mm strong tension rods with double washers
- Batter Side Edge Ring : Lightweight Magnesium Edge Ring for super high-pitch tuning
- Bottom Side Edge : With reinforcement ring
- Snare Guts : 11 Guts with Detachable Gut Frame
- Snare Mutes : 2 Buzz Killer Mutes included
- Hoops : Aluminum die-cast hoop
- Hardware Finish : Chrome
- Shell Finishes : 17 lacquer finishes & 1 wrap finish
- Stable Position Ring : Allows for easy replacement of the bottom head
- Legs : 2 aluminum legs prevent damage to the bottom hoop

Lacquer Finishes

Model No.	Size		
MS1409L	14"x9" MARCHING SNARE DRUM		462.000,00
MS1412L	14"x12" MARCHING SNARE DRUM		462.000,00

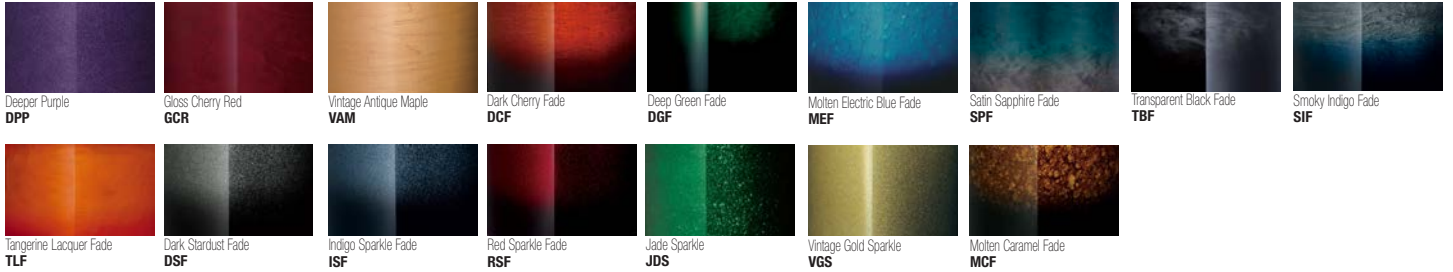

Lacquer Finish -Satin Black-

Model No.	Size		
MS1409T	14"x9" MARCHING SNARE DRUM		392.000,00
MS1412T	14"x12" MARCHING SNARE DRUM		392.000,00



Satin Black
SBK

Wrap Finish -Sugar White-

Model No.	Size		
MS1409K	14"x9" MARCHING SNARE DRUM		392.000,00
MS1412K	14"x12" MARCHING SNARE DRUM		392.000,00



Sugar White
SGW

FIELDSTAR RUDIMENT MARCHING TENOR DRUMS



Color: Satin Black (SBK)

MD680234T

- Shell Materials : Maple 6ply 5mm w/reinforcement rings on batter side
- Shell Depth :
- Spock 6"x5.5", 6"x7", 8"x7"
- Standard Toms 8"x7.5", 10"x8", 12"x9.5", 13"x11", 14x11.5" with Power Cut
- Corps Depth Toms: 10"x9.5", 12"x11", 13"x12.5", 14"x13" with Power Cut
- Lugs : Die-cast aluminum lugs
- Number of Lugs : 6" = 4, 8" = 5, 10" = 6, 12", 13", 14" = 8
- Hoops : 2.3 mm Steel Mighty Hoop
- Edge Guard : Included
- Shell Inside : Clear painted to protect inner shell
- Shell Finishes : 17 lacquer finishes & 1 wrap finish
- Hardware Finish : Chrome

Lacquer Finishes

Model No.	Size	
MT8023L	8"-10"-12"-13" SMALL QUAD DRUMS	735.000,00
MT0234L	10"-12"-13"-14" LARGE QUAD DRUMS	797.000,00
MT68023L	6"-8"-10"-12"-13" SMALL QUINT DRUMS	839.000,00
MT60234L	6"-10"-12"-13"-14" LARGE QUINT DRUMS	904.000,00
MD60234L	6"-10"-12"-13"-14" LARGE QUINT DRUMS (CORP-DEPTH)	904.000,00
MT80234L	8"-10"-12"-13"-14" LARGE QUINT DRUMS	916.000,00
MT668023L	6"-6"-8"-10"-12"-13" SMALL SEXTET DRUMS	966.000,00
MT660234L	6"-6"-10"-12"-13"-14" LARGE SEXTET DRUMS	1.008.000,00
MD660234L	6"-6"-10"-12"-13"-14" LARGE SEXTET DRUMS (CORP-DEPTH)	1.008.000,00
MT680234L	6"-8"-10"-12"-13"-14" LARGE SEXTET DRUMS	1.035.000,00
MD680234L	6"-8"-10"-12"-13"-14" LARGE SEXTET DRUMS (CORP-DEPTH)	1.035.000,00
MT602L	6"-10"-12" TRIO DRUMS	593.000,00

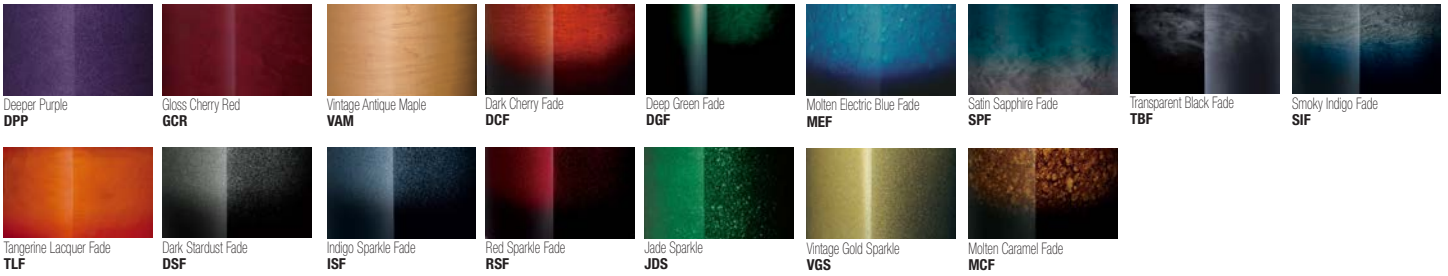

Lacquer Finish -Satin Black-

Model No.	Size	
MT8023T	8"-10"-12"-13" SMALL QUAD DRUMS	554.000,00
MT0234T	10"-12"-13"-14" LARGE QUAD DRUMS	593.000,00
MT68023T	6"-8"-10"-12"-13" SMALL QUINT DRUMS	639.000,00
MT60234T	6"-10"-12"-13"-14" LARGE QUINT DRUMS	677.000,00
MD60234T	6"-10"-12"-13"-14" LARGE QUINT DRUMS (CORP-DEPTH)	677.000,00
MT80234T	8"-10"-12"-13"-14" LARGE QUINT DRUMS	681.000,00
MT668023T	6"-6"-8"-10"-12"-13" SMALL SEXTET DRUMS	716.000,00
MT660234T	6"-6"-10"-12"-13"-14" LARGE SEXTET DRUMS	754.000,00
MD660234T	6"-6"-10"-12"-13"-14" LARGE SEXTET DRUMS (CORP-DEPTH)	754.000,00
MT680234T	6"-8"-10"-12"-13"-14" LARGE SEXTET DRUMS	789.000,00
MD680234T	6"-8"-10"-12"-13"-14" LARGE SEXTET DRUMS (CORP-DEPTH)	789.000,00
MT602T	6"-10"-12" TRIO DRUMS	458.000,00



Satin Black
SBK

Wrap Finish -Sugar White-

Model No.	Size	
MT8023K	8"-10"-12"-13" SMALL QUAD DRUMS	554.000,00
MT0234K	10"-12"-13"-14" LARGE QUAD DRUMS	593.000,00
MT68023K	6"-8"-10"-12"-13" SMALL QUINT DRUMS	639.000,00
MT60234K	6"-10"-12"-13"-14" LARGE QUINT DRUMS	677.000,00
MD60234K	6"-10"-12"-13"-14" LARGE QUINT DRUMS (CORP-DEPTH)	677.000,00
MT80234K	8"-10"-12"-13"-14" LARGE QUINT DRUMS	681.000,00
MT668023K	6"-6"-8"-10"-12"-13" SMALL SEXTET DRUMS	716.000,00
MT660234K	6"-6"-10"-12"-13"-14" LARGE SEXTET DRUMS	754.000,00
MD660234K	6"-6"-10"-12"-13"-14" LARGE SEXTET DRUMS (CORP-DEPTH)	754.000,00
MT680234K	6"-8"-10"-12"-13"-14" LARGE SEXTET DRUMS	789.000,00
MD680234K	6"-8"-10"-12"-13"-14" LARGE SEXTET DRUMS (CORP-DEPTH)	789.000,00
MT602K	6"-10"-12" TRIO DRUMS	458.000,00



Sugar White
SGW

FIELDSTAR FREEDOM MARCHING TENOR DRUMS



Color: Molten Caramel Fade (MCF)

M668023TL

- Shell Materials : Maple 6ply 5mm w/reinforcement rings on batter side
- Shell Depth :
- Spock 6"x5.5", 6"x7", 8"x7"
- Standard Toms 8"x7.5", 10"x8", 12"x9.5", 13"x11", 14x11.5" with Power Cut
- Corps Depth Toms: 10"x9.5", 12"x11", 13"x12.5", 14"x13" with Power Cut
- Lugs : Die-cast aluminum lugs
- Number of Lugs : 6" = 4, 8" = 5, 10" = 6, 12", 13", 14" = 8
- Hoops : 2.3 mm Steel Mighty Hoop
- Edge Guard : Included
- Adjusting Tom Angle : Adjusts by loosening 4 screws with tuning key
- Legs : Three Detachable Legs
- Shell Inside : Clear painted to protect inner shell
- Shell Finishes : 17 lacquer finishes & 1 wrap finish
- Hardware Finish : Chrome

Lacquer Finishes

Model No.	Size		
M8023TL	8"-10"-12"-13" QUAD DRUMS		735.000,00
M68023TL	6"-8"-10"-12"-13" QUINT DRUMS		839.000,00
M668023TL	6"-6"-8"-10"-12"-13" SEXTET DRUMS		966.000,00
M0234TL	10"-12"-13"-14" QUAD DRUMS		797.000,00
M60234TL	6"-10"-12"-13"-14" QUINT DRUMS		904.000,00
M60234DL	6"-10"-12"-13"-14" QUINT DRUMS (CORP-DEPTH)		904.000,00
M80234TL	8"-10"-12"-13"-14" QUINT DRUMS		916.000,00
M660234TL	6"-6"-10"-12"-13"-14" SEXTET DRUMS		1.008.000,00
M660234DL	6"-6"-10"-12"-13"-14" SEXTET DRUMS (CORP-DEPTH)		1.008.000,00
M680234TL	6"-8"-10"-12"-13"-14" SEXTET DRUMS		1.035.000,00
M680234DL	6"-8"-10"-12"-13"-14" SEXTET DRUMS (CORP-DEPTH)		1.035.000,00
M4TL	14"x11.5" SOLO TENOR DRUM		285.000,00

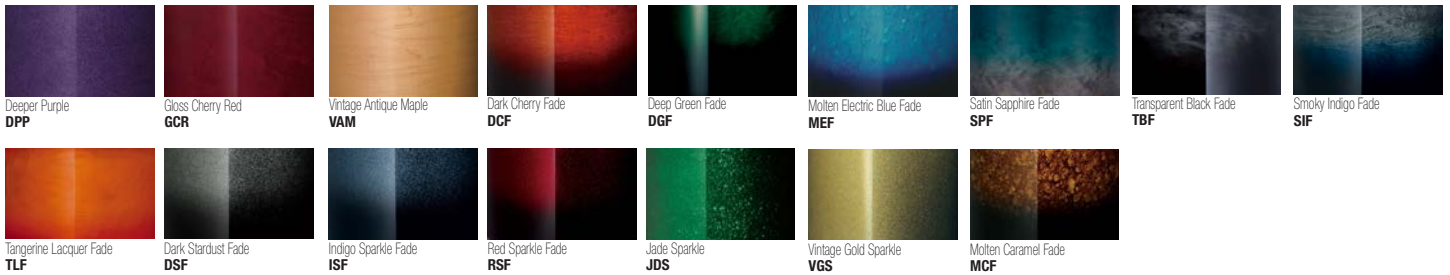

Lacquer Finish -Satin Black-

Model No.	Size		
M8023TT	8"-10"-12"-13" QUAD DRUMS		554.000,00
M68023TT	6"-8"-10"-12"-13" QUINT DRUMS		639.000,00
M668023TT	6"-6"-8"-10"-12"-13" SEXTET DRUMS		716.000,00
M0234TT	10"-12"-13"-14" QUAD DRUMS		593.000,00
M60234TT	6"-10"-12"-13"-14" QUINT DRUMS		677.000,00
M60234DT	6"-10"-12"-13"-14" QUINT DRUMS (CORP-DEPTH)		677.000,00
M80234TT	8"-10"-12"-13"-14" QUINT DRUMS		681.000,00
M660234TT	6"-6"-10"-12"-13"-14" SEXTET DRUMS		754.000,00
M660234DT	6"-6"-10"-12"-13"-14" SEXTET DRUMS (CORP-DEPTH)		754.000,00
M680234TT	6"-8"-10"-12"-13"-14" SEXTET DRUMS		789.000,00
M680234DT	6"-8"-10"-12"-13"-14" SEXTET DRUMS (CORP-DEPTH)		789.000,00
M4TT	14"x11.5" SOLO TENOR DRUM		211.000,00



Satin Black
SBK

Wrap Finish -Sugar White-

Model No.	Size		
M8023TK	8"-10"-12"-13" QUAD DRUMS		554.000,00
M68023TK	6"-8"-10"-12"-13" QUINT DRUMS		639.000,00
M668023TK	6"-6"-8"-10"-12"-13" SEXTET DRUMS		716.000,00
M0234TK	10"-12"-13"-14" QUAD DRUMS		593.000,00
M60234TK	6"-10"-12"-13"-14" QUINT DRUMS		677.000,00
M60234DK	6"-10"-12"-13"-14" QUINT DRUMS (CORP-DEPTH)		677.000,00
M80234TK	8"-10"-12"-13"-14" QUINT DRUMS		681.000,00
M660234TK	6"-6"-10"-12"-13"-14" SEXTET DRUMS		754.000,00
M660234DK	6"-6"-10"-12"-13"-14" SEXTET DRUMS (CORP-DEPTH)		754.000,00
M680234TK	6"-8"-10"-12"-13"-14" SEXTET DRUMS		789.000,00
M680234DK	6"-8"-10"-12"-13"-14" SEXTET DRUMS (CORP-DEPTH)		789.000,00
M4TK	14"x11.5" SOLO TENOR DRUM		211.000,00



Sugar White
SGW

FIELDSTAR MARCHING BASS DRUMS



Color: Satin Black (SBK)

MB2214T

- Shell Materials : Maple 8ply 6mm
- Weight :
 - MB1414 14"x14" 14.5lbs (6.6kg)
 - MB1614 16"x14" 15.7lbs (7.1kg)
 - MB1814 18"x14" 16.5lbs (7.5kg)
 - MB2014 20"x14" 19.0lbs (8.6kg)
 - MB2214 22"x14" 20.1lbs (9.1kg)
 - MB2414 24"x14" 21.3lbs (9.7kg)
 - MB2614 26"x14" 22.5lbs (10.2kg)
 - MB2814 28"x14" 23.7lbs (10.8kg)
 - MB3014 30"x14" 24.9lbs (11.3kg)

- Attachment for carrier : Noiseless carrier attachment
- Lugs : Die-cast aluminum high-tension lugs
- Number of lugs : 14" - 18" = 8 lugs, 20" - 28" = 10 lugs, 30" = 12 lugs
- Claw Hooks : Designed with superior strength for high-pitch tuning
- Hoops : High-gloss black lacquer finish
- Shell Finishes : 17 lacquer finishes & 1 wrap finish
- Hardware Finish : Chrome

Lacquer Finishes

Model No.	Size		
MB1414L	14"x14" MARCHING BASS DRUM		346.000,00
MB1614L	16"x14" MARCHING BASS DRUM		373.000,00
MB1814L	18"x14" MARCHING BASS DRUM		404.000,00
MB2014L	20"x14" MARCHING BASS DRUM		477.000,00
MB2214L	22"x14" MARCHING BASS DRUM		492.000,00
MB2414L	24"x14" MARCHING BASS DRUM		531.000,00
MB2614L	26"x14" MARCHING BASS DRUM		569.000,00
MB2814L	28"x14" MARCHING BASS DRUM		600.000,00
MB3014L	30"x14" MARCHING BASS DRUM w/o drum heads		785.000,00

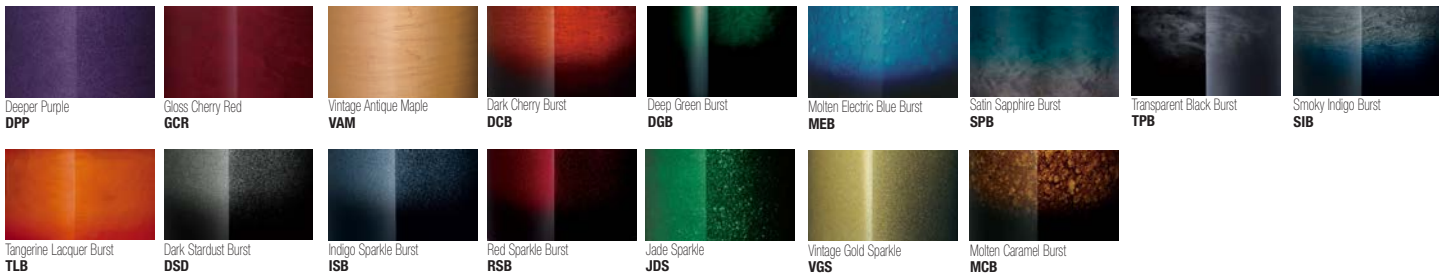

Lacquer Finishes -Satin Black-

Model No.	Size		
MB1414T	14"x14" MARCHING BASS DRUM		265.000,00
MB1614T	16"x14" MARCHING BASS DRUM		288.000,00
MB1814T	18"x14" MARCHING BASS DRUM		323.000,00
MB2014T	20"x14" MARCHING BASS DRUM		362.000,00
MB2214T	22"x14" MARCHING BASS DRUM		373.000,00
MB2414T	24"x14" MARCHING BASS DRUM		392.000,00
MB2614T	26"x14" MARCHING BASS DRUM		435.000,00
MB2814T	28"x14" MARCHING BASS DRUM		450.000,00
MB3014T	30"x14" MARCHING BASS DRUM w/o drum heads		554.000,00



Wrap Finish -Sugar White-

Model No.	Size		
MB1414K	14"x14" MARCHING BASS DRUM		265.000,00
MB1614K	16"x14" MARCHING BASS DRUM		288.000,00
MB1814K	18"x14" MARCHING BASS DRUM		323.000,00
MB2014K	20"x14" MARCHING BASS DRUM		362.000,00
MB2214K	22"x14" MARCHING BASS DRUM		373.000,00
MB2414K	24"x14" MARCHING BASS DRUM		392.000,00
MB2614K	26"x14" MARCHING BASS DRUM		435.000,00
MB2814K	28"x14" MARCHING BASS DRUM		450.000,00
MB3014K	30"x14" MARCHING BASS DRUM w/o drum heads		554.000,00



STARLIGHT MARCHING SNARE DRUMS



Color: Satin Black (SBK)

R1412SL

- Shell : Birch 8mm 8ply
- Hoop : 2.3mm Steel Mighty Hoop
- Number of Lugs : 12 lugs with aluminum tube pipes
- Strainer : Quick touch snare strainer
- Batter Side Edge Ring : Aluminum die-cast edge ring for super high-pitch tuning
- Snare Wires : 20-strand Carbon Steel Snappy Snares

Lacquer Finish -Satin Black-

Model No.	Size		
R1412SL	14"x12" MARCHING SNARE DRUM		211.000,00

Satin Black
SBK

Wrap Finish -Sugar White-

Model No.	Size		
R1412SK	14"x12" MARCHING SNARE DRUM		208.000,00

Sugar White
SGW

STARLIGHT MARCHING TENOR DRUMS



Color: Sugar White (SGW)

R8023TK

- Shell : Birch 8mm 8ply
- Hoop : 1.6mm Steel Triple Flanged
- Adjusting Tom Angle (for Quad)
- Edge Guard included

Lacquer Finish -Satin Black-

Model No.	Size		
R8023TL	8"-10"-12"-13" QUAD DRUMS		323.000,00
R802TL	8"-10"-12" TRIO DRUMS		242.000,00
R4TL	14"x11.5" SOLO TENOR DRUM		146.000,00
R0655TLP	6"x5.5" TOM FOR TENOR DRUM		57.000,00

Wrap Finish -Sugar White-

Model No.	Size		
R8023TK	8"-10"-12"-13" QUAD DRUMS		311.000,00
R802TK	8"-10"-12" TRIO DRUMS		238.000,00
R4TK	14"x11.5" SOLO TENOR DRUM		138.000,00
R0655TKP	6"x5.5" TOM FOR TENOR DRUM		57.000,00

STARLIGHT MARCHING BASS DRUMS



Color: Sugar White (SGW)

R2214BK

- Shell : Birch 7mm 7ply
- Attachment for carrier : Noiseless carrier attachment
- Lug : Die-cast aluminum high-tension lugs
- Number of lugs : 16" - 18" = 8 lugs, 20" - 28" = 10 lugs
- Claw Hook : Designed with superior strength for high-pitch tuning
- Hoop : High-gloss black lacquer finish

Lacquer Finish -Satin Black-

Model No.	Size		
R1614BL	16"x14" MARCHING BASS DRUM		223.000,00
R1814BL	18"x14" MARCHING BASS DRUM		238.000,00
R2014BL	20"x14" MARCHING BASS DRUM		273.000,00
R2214BL	22"x14" MARCHING BASS DRUM		285.000,00
R2414BL	24"x14" MARCHING BASS DRUM		296.000,00
R2614BL	26"x14" MARCHING BASS DRUM		327.000,00
R2814BL	28"x14" MARCHING BASS DRUM		342.000,00

Wrap Finish -Sugar White-

Model No.	Size		
R1614BK	16"x14" MARCHING BASS DRUM		219.000,00
R1814BK	18"x14" MARCHING BASS DRUM		234.000,00
R2014BK	20"x14" MARCHING BASS DRUM		269.000,00
R2214BK	22"x14" MARCHING BASS DRUM		281.000,00
R2414BK	24"x14" MARCHING BASS DRUM		292.000,00
R2614BK	26"x14" MARCHING BASS DRUM		323.000,00
R2814BK	28"x14" MARCHING BASS DRUM		331.000,00

Satin Black
SBK

Sugar White
SGW

SILVER ARMOR CARRIER FOR SNARE DRUM



CSASDT

- Sliding Height Adjustment
- Safety Lock Mount
- Positioning Bar
- Belly Pad
- Shoulder Pipe Adjustment
- Backrest Adjustment
- Movable Pad

181.000,00

SILVER ARMOR CARRIER FOR TENOR DRUM



CSATNT

- Sliding Height Adjustment
- Safety Lock Mount
- Positioning Bar
- Drum Lift Bumper
- Belly Pad
- Shoulder Pipe Adjustment
- Backrest Adjustment
- Movable Pad

181.000,00

SILVER ARMOR CARRIER FOR BASS DRUM



CSABDT

- Sliding Height Adjustment
- Safety Lock Mount
- Two-way Support Bar
- Belly Pad
- Shoulder Pipe Adjustment
- Backrest Adjustment
- Movable Pad

181.000,00

SILVER ARMOR CARRIER "J-BAR TYPE" FOR SNARE DRUM



CSASDM

- Sliding Height Adjustment
- Belly Pad
- Shoulder Pipe Adjustment
- Backrest Adjustment
- Movable Pad
- Suitable for general J-bar type carrier for Snare drums that have 14mm diameter rod
- Not fit to Tama Marching Snare Drums

181.000,00

SILVER ARMOR CARRIER "J-BAR TYPE" FOR TENOR DRUM



CSATNM

- Sliding Height Adjustment
- Drum Lift Bumper
- Belly Pad
- Shoulder Pipe Adjustment
- Backrest Adjustment
- Movable Pad
- Suitable for general J-bar type carrier for Tenor drums that have 14mm diameter rod
- Not fit to Tama Marching Tenor Drums

181.000,00

SILVER ARMOR CARRIER "HOOK TYPE" FOR BASS DRUM



CSABDM

- Sliding Height Adjustment
- Two-way Support Bar
- Belly Pad
- Shoulder Pipe Adjustment
- Backrest Adjustment
- Movable Pad
- Suitable for general locking type of carrier for bass drum with eyebolt. The distance between eyebolt hook can be adjustable within the range from 165mm to 250mm.
- Not fit to Tama Marching Bass Drums

181.000,00

STARLIGHT CARRIER FOR SNARE DRUM



CRSDT

- Sliding Height Adjustment
- Safety Lock Mount

119.000,00

STARLIGHT CARRIER FOR TENOR DRUM



CRTNT

- Sliding Height Adjustment
- Safety Lock Mount

119.000,00

STARLIGHT CARRIER FOR BASS DRUM



CRBDT

- Sliding Height Adjustment
- Safety Lock Mount
- Two-way Support Bar

119.000,00

SAFETY LOCK MARCHING STAND FOR SNARE DRUM



HMSD79WSN

- Snare Anti-Shake Bumper
- Upside Down Setting
- Safety Lock Mount
- Center of Gravity Position
- Adjustable 2 Front Legs
- Glide-Tite Grip Joint
- Double Braced Legs

111.000,00

SAFETY LOCK MARCHING STAND FOR TENOR DRUM



HMTN79WSZ

- Fold and Positioning Bar
- Tenor Anti-Chace Support Bar
- Safety Lock Mount
- Center of Gravity Position
- Adjustable 2 Front Legs
- Glide-Tite Grip Joint
- Double Braced Legs

123.000,00

UNIVERSAL MARCHING STAND FOR BASS DRUM



HMBD79WSM

- Center of Gravity Position
- Adjustable 2 Front Legs
- Glide-Tite Grip Joint
- Double Braced Legs

107.000,00

SAFETY LOCK MARCHING NON STADIUM STAND FOR SNARE DRUM



HMSD79WN

- Snare Anti-Shake Bumper
- Upside Down Setting
- Safety Lock Mount
- Center of Gravity Position
- Glide-Tite Grip Joint
- Double Braced Legs

92.000,00

SAFETY LOCK MARCHING NON STADIUM STAND FOR TENOR DRUM



HMTN79WZ

- Fold and Positioning Bar
- Tenor Anti-Shake Support Bar
- Safety Lock Mount
- Center of Gravity Position
- Glide-Tite Grip Joint
- Double Braced Legs

111.000,00

UNIVERSAL NON STADIUM MARCHING STAND FOR BASS DRUM



HMBD79WM

- Center of Gravity Position
- Glide-Tite Grip Joint
- Double Braced Legs

100.000,00

MARCHING DRUM PROTECT COVERS FOR SNARE DRUM



CVS1412N

CVS1412N (for 14"x12" Snare Drum)

11.100,00

MARCHING DRUM PROTECT COVERS FOR TENOR DRUM



CVTL

17.700,00

MARCHING DRUM PROTECT COVERS FOR BASS DRUM



CVB2224N

CVB1416N (for 14"x16" Bass Drum)
CVB1820N (for 18"x20" Bass Drum)
CVB2224N (for 22"x24" Bass Drum)
CVB2628N (for 26"x28" Bass Drum)
CVB30N (for 30" Bass Drum)

181.000,00

HOOP GRIP & Z-ROD FOR HI-HAT CYMBALS



MC8ZH

Hoop Grip (MC8) & Z-Rod for Hi-Hat Cymbals (ZH) bundle package

28.500,00

Z-ROD FOR HI-HAT CYMBALS



ZHH

Z-rod for mounting Hi-Hat cymbals

Details:
- Screw Type Hi-Hat Clutch

17.300,00

SNARE PROJECTER



TPS14W

For 14" Snare Drums

TPS14W (White)
TPS14B2 (Black)
TPS14C (Clear)

16.900,00

BASS DRUM HOOP GUARD



MBRG14

TAMA Hoop Guards can be securely locked to bass drum hoops using the friction of rubber cushions. The rubber cushions protect the hoops from scratches and the Hoop Guards protect the hoops from rim shots.

8.860,00

BASS DRUM HOOP GUARD



MBHG100

TAMA Hoop Guards can be securely locked to bass drum hoops. The rubber cushions protect the hoops from scratches and the Hoop Guards protect the hoops from rim shots.

9.630,00

Bass Drum Mallet Holder



MBMH100

This mallet holder holds the 2 pairs of mallets by secure and easy retaining system. Also attaching this unit to bass drum without any screws tightening

38.100,00

TAMA LOGO STICKER -White-



TLS100WH

TLS120WH 60mm x 280mm

1.810,00

TLS100WH 50mm x 230mm

1.690,00

TLS80WH 40mm x 190mm

1.690,00

TLS70WH 35mm x 150mm

1.690,00

TAMA LOGO STICKER -Black-



TLS100BK

TLS120BK 60mm x 280mm

1.810,00

TLS100BK 50mm x 230mm

1.690,00

TLS80BK 40mm x 190mm

1.690,00

TLS70BK 35mm x 150mm

1.690,00

GUT FRAME ASSEMBLY



MGF14BR

TAMA Brown Guts are produce a crisp and warm sound. The gut frame can be instantly changed to produce the sound of your choice.

48.000,00

SNARE MUTE



MSMT

8.860,00

MULTI LOCK CLAMP



MLC79

20.000,00

BASS DRUM MUFFLE RINGS



MBSP2

(2pcs/set)

6.930,00

TURNING KEY



THDK20

Hi-Tension Tuning Key

6.930,00

BACK SUPPORT BELT FOR CARRIER



CSABS

The Back Support Belt gives extra support while reducing back stress. Designed to be used with TAMA Silver Armor Carriers, (sold separately), it can be easily adjusted for different body types and is removable.

14.200,00

CONCERT PERCUSSION

We offer Concert Percussion lineup with snare drums, toms, and hardwares.

STARPHONIC Concert Snare Drums are built to the absolute pinnacle of quality and design, and they carry a sound that's to be expected from any instrument bearing the name TAMA.

BILL PLATT SIGNATURE



BP146

MADE IN JAPAN

Shell: 3mm Bell Brass w/3 Air Vents
Size: 14"x6"
Lug: Freedom Lug
Hoop: Grooved Straight Hoop (10 tension)
Strainer: MLS50AD/MLS50BD w/ Multi Snare Frame
Snare Wire: Three Different Snare Wire
Nickel Wound Round Guitar String (MS6NW14M, 6 strands)
Black Nylon Coated Stainless Steel Wire

916.000,00

STARPHONIC MAPLE BRAVURA CONCERT



Color: Gloss Mocha Brown -GMC

CMP146MF

MADE IN JAPAN

Shell: 6mm, 7ply 100% Maple
Size: 14"x6"
Lug: Freedom Lug
Hoop: Grooved Straight Hoop (10 hole)
Strainer/Butt: MLS50AD/MLS50BD w/Multi Snare Frame
Snare Wire: Three Different Snare Wire
Nickel Wound Round Guitar String (6 strands)

335.000,00

STARPHONIC MAPLE CONCERT



Color: Piano Black -PBK

CMP146

MADE IN JAPAN

Shell: 6mm, 7ply 100% Maple
Size: 14"x6"
Lug: Freedom Lug
Hoop: Grooved Straight Hoop (10 hole)
Strainer/Butt: MLS50AC/MLS50BC w/Fine Adjuster
Snare Wire: Hybrid Snare Wire
Nickel Wound Round Guitar String (6 strands in the center)

250.000,00

STARPHONIC BUBINGA BRAVURA CONCERT



Color: Gloss Natural Cordia -GNC

CBC146MF

MADE IN JAPAN

Shell: 7mm, 7ply 100% Bubinga + 1 outer ply Cordia
Size: 14" x 6"
Lug: Freedom Lug
Hoop: Grooved Straight Hoop (10 hole)
Strainer/Butt: MLS50AD/MLS50BD w/ Multi Snare Frame
Snare Wire: Three Different Snare Wire
Nickel Wound Round Guitar String (6 strands)

373.000,00

STARPHONIC ALUMINUM BRAVURA CONCERT



CAL146MF

MADE IN JAPAN

Shell: 3mm Aluminum
Size: 14"x6"
Lug: Freedom Lug
Hoop: Grooved Straight Hoop
Strainer/Butt: MLS50AD / MLS50BD w/Multi Snare Frame
Snare Wire: Three Different Snare Wire
Nickel Wound Round Guitar String (6 strands)

373.000,00

STARPHONIC ALUMINUM CONCERT



CAL146

MADE IN JAPAN

Shell: 3mm Aluminum
Size: 14"x6"
Lug: Freedom Lug
Hoop: Grooved Straight Hoop
Strainer/Butt: MLS50AC / MLS50BC w/Fine Adjuster
Snare Wire: Hybrid Snare Wire

288.000,00

STARPHONIC WALNUT BRAVURA FIELD DRUM



Color: Gloss Black Walnut (GBW)

CWN1414MF

MADE IN JAPAN

Shell: 6mm, 6ply 100% Walnut
 Size: 14"x14"
 Lug: Freedom Lug
 Hoop: Grooved Straight Hoop (10 hole)
 Strainer/Butt: MLS50AD/MLS50BD w/Multi Snare Frame
 Snare Wire: Three Different Snare Wire
 Nickel Wound Round Guitar String (6 strands)

458.000,00

CONCERT MAPLE



Color: Piano Black (PBK)

CLMP1465

Shell: 6mm, 7ply 100% Maple
 Size: 14"x6.5"
 Lug: MTL60
 Hoop: Steel Mighty Hoop (10 hole)
 Strainer/Butt: MLS50AC/MLS50BC w/Fine Adjuster
 Snare Wire: Hybrid Snare Wire
 Nickel Wound Round Guitar String (6 strands in the center)

173.000,00

CONCERT MAPLE



Color: Vintage Antique Maple (VAM)

CLMP145

Shell: 6mm, 7ply 100% Maple
 Size: 14"x5"
 Lug: MTL50
 Hoop: Steel Mighty Hoop (10 hole)
 Strainer/Butt: MLS50AC/MLS50BC w/Fine Adjuster
 Snare Wire: Hybrid Snare Wire
 Nickel Wound Round Guitar String (6 strands in the center)

165.000,00

CONCERT TOM SET -SINGLE HEAD-



Color: Vintage Antique Maple -VAM-

CSLT4H

High-Pitched Concert Tom Set
 6"x6" Tom Tom, 8"x7" Tom Tom, 10"x8" Tom Tom, 12"x9" Tom Tom
 - 100% Maple Shell
 - Direct-Flexi Mount
 [Available Finishes]
 -Vintage Antique Maple (VAM)
 -Transparent Black Fade (TBF)

242.000,00

CONCERT TOM SET -SINGLE HEAD-



Color: Vintage Antique Maple -VAM-

CSLT4M

Mid-Pitched Concert Tom Set
 10"x8" Tom Tom, 12"x9" Tom Tom, 13"x11" Tom Tom, 14"x12" Tom Tom
 - 100% Maple Shell
 - Direct-Flexi Mount
 [Available Finishes]
 -Vintage Antique Maple (VAM)
 -Transparent Black Fade (TBF)

288.000,00

CONCERT TOM SET -SINGLE HEAD-



Color: Vintage Antique Maple -VAM-

CSLT4L

Low-Pitched Concert Tom Set
 12"x10" Tom Tom, 13"x11" Tom Tom, 14"x12" Tom Tom, 16"x13" Tom Tom
 - 100% Maple Shell
 - Direct-Flexi Mount
 [Available Finishes]
 -Vintage Antique Maple (VAM)
 -Transparent Black Fade (TBF)

327.000,00

CONCERT TOM -SINGLE HEAD-



Color: Vintage Antique Maple -VAM-

CSLT6A

6"x6" Tom Tom

[Available Finishes]
 --Vintage Antique Maple (VAM)
 -Transparent Black Fade (TBF)

57.000,00

CONCERT TOM -SINGLE HEAD-



Color: Vintage Antique Maple -VAM-

CSLT8A

8"x7" Tom Tom

[Available Finishes]
 --Vintage Antique Maple (VAM)
 -Transparent Black Fade (TBF)

61.000,00

CONCERT TOM -SINGLE HEAD-



Color: Vintage Antique Maple -VAM-

CSLT10A

10"x8" Tom Tom

[Available Finishes]
 --Vintage Antique Maple (VAM)
 -Transparent Black Fade (TBF)

69.000,00

CONCERT TOM -SINGLE HEAD-



Color: Vintage Antique Maple -VAM-

CSLT12A

12"x9" Tom Tom

[Available Finishes]
 --Vintage Antique Maple (VAM)
 -Transparent Black Fade (TBF)

77.000,00

CONCERT TOM -SINGLE HEAD-



Color: Vintage Antique Maple -VAM-

CSLT12D

12"x10" Tom Tom

[Available Finishes]
 -Vintage Antique Maple (VAM)
 -Transparent Black Fade (TBF)

77.000,00

CONCERT TOM -SINGLE HEAD-



Color: Vintage Antique Maple -VAM-

CSLT13D

13"x11" Tom Tom

[Available Finishes]
 -Vintage Antique Maple (VAM)
 -Transparent Black Fade (TBF)

84.000,00

CONCERT TOM -SINGLE HEAD-



CSLT14D

14"x12" Tom Tom

[Available Finishes]
-Vintage Antique Maple (VAM)
-Transparent Black Fade (TBF)

92.000,00

Color: Vintage Antique Maple -VAM-

CONCERT TOM -SINGLE HEAD-



CSLT16D

16"x14" Tom Tom

[Available Finishes]
-Vintage Antique Maple (VAM)
-Transparent Black Fade (TBF)

115.000,00

Color: Vintage Antique Maple -VAM-

CONCERT TOM SET -DOUBLE HEAD-



CCLT4H

High-Pitched Concert Tom Set
6"x6" Tom Tom, 8"x7" Tom Tom, 10"x8" Tom Tom, 12"x9" Tom Tom

- 100% Maple Shell
- Direct-Flexi Mount
[Available Finishes]
-Vintage Antique Maple (VAM)
-Transparent Black Burst (TPB)

261.000,00

Color: Transparent Black Burst -TPB-

CONCERT TOM SET -DOUBLE HEAD-



CCLT4M

Mid-Pitched Concert Tom Set
10"x8" Tom Tom, 12"x9" Tom Tom, 13"x11" Tom Tom, 14"x12" Tom Tom

- 100% Maple Shell
- Direct-Flexi Mount
[Available Finishes]
-Vintage Antique Maple (VAM)
-Transparent Black Burst (TPB)

308.000,00

Color: Transparent Black Burst -TPB-

CONCERT TOM SET -DOUBLE HEAD-



CCLT4L

Low-Pitched Concert Tom Set
12"x10" Tom Tom, 13"x11" Tom Tom, 14"x12" Tom Tom, 16"x14" Tom Tom

- 100% Maple Shell
- Direct-Flexi Mount
[Available Finishes]
-Vintage Antique Maple (VAM)
-Transparent Black Burst (TPB)

346.000,00

Color: Transparent Black Burst -TPB-

CONCERT TOM -DOUBLE HEAD-



CCLT6A

6"x6" Tom Tom

[Available Finishes]
-Vintage Antique Maple (VAM)
-Transparent Black Burst (TPB)

61.000,00

Color: Transparent Black Burst -TPB-

CONCERT TOM -DOUBLE HEAD-



CCLT8A

8"x7" Tom Tom

[Available Finishes]
-Vintage Antique Maple (VAM)
-Transparent Black Burst (TPB)

65.000,00

Color: Transparent Black Burst -TPB-

CONCERT TOM -DOUBLE HEAD-



CCLT10A

10"x8" Tom Tom

[Available Finishes]
-Vintage Antique Maple (VAM)
-Transparent Black Burst (TPB)

73.000,00

Color: Transparent Black Burst -TPB-

CONCERT TOM -DOUBLE HEAD-



CCLT12A

12"x9" Tom Tom

[Available Finishes]
-Vintage Antique Maple (VAM)
-Transparent Black Burst (TPB)

80.000,00

Color: Transparent Black Burst -TPB-

CONCERT TOM -DOUBLE HEAD-



CCLT12D

12"x10" Tom Tom

[Available Finishes]
-Vintage Antique Maple (VAM)
-Transparent Black Burst (TPB)

80.000,00

Color: Transparent Black Burst -TPB-

CONCERT TOM -DOUBLE HEAD-



CCLT13D

13"x11" Tom Tom

[Available Finishes]
-Vintage Antique Maple (VAM)
-Transparent Black Burst (TPB)

88.000,00

Color: Transparent Black Burst -TPB-

CONCERT TOM -DOUBLE HEAD-



CCLT14D

14"x12" Tom Tom

[Available Finishes]
-Vintage Antique Maple (VAM)
-Transparent Black Burst (TPB)

104.000,00

Color: Transparent Black Burst -TPB-

CONCERT TOM -DOUBLE HEAD-



Color: Transparent Black Burst -TPB-

CCLT16D

16"x14" Tom Tom

[Available Finishes]
-Vintage Antique Maple (VAM)
-Transparent Black Burst (TPB)

119.000,00

CONCERT SNARE STAND - ROADPRO



HS80HWN

For 12" to 15" Diameter Snare Drums

-Quick-Set Tilter
-Swiveling Basket
-Glide-Tite Grip Joint
-Double Braced Legs
-Weight: 3.7kg (8.2lbs)
-Height Adjustment Range: 640mm - 925mm
(25 3/16" - 36 3/8")

50.000,00

CONCERT SNARE STAND - THE CLASSIC STAND



HS50HF

-Flat Base Leg Design
-Classic Style Basket
-Double Braced Arms
-Gearless Tilter
-Weight: 1.9kg (4.2lbs)
-Height Adjustment Range: 630mm-860mm (24 13/16" - 33 7/8")

34.300,00

DOUBLE TOM STAND



HTW839W

-28.6mm Diameter Base Section Tubing
-Omni-Ball Tom Angle Adjustment
-Stilt System
-Glide-Tite Grip Joint
-Double Braced Legs
-Weight: 5.0kg (11 lbs)
-Height Adjustment Range: 790-1,270mm (31 1/8" - 50")

96.000,00

PERCUSSION TABLE



HTB86LS

-25.4mm Diameter Base Section Tubing
-Table Size: 600mm width x 450mm length
-Glide-Tite Grip Joint
-Single Braced Legs
-Weight: 5.5kg (12.1lbs)

80.000,00

POWERPAD BAG -Concert Snare Drum-



PBSC146

-For Tama Concert Snare Drum
-Five-Layered Semi-Hard Resin Structure
-30mm Groove to Securely House Multi Snare Frame

43.000,00

"Model" stands for the item number as used by Roland Meinl Musikinstrumente GmbH & Co KG ("Meinl").
Each price as specified is the manufacturer's suggested retail price (MSRP), applicable as of 10.01.2024 and subject to change.
Dealers and other resellers remain free to set their own retail prices at all times.
Price and model changes as well as changes to technical data are reserved without prior announcement.
No liability is assumed for setting, printing and colour errors.

Roland Meinl Musikinstrumente GmbH & Co. KG | Musik-Meinl Str. 1 | 91468 Gutenstetten | Germany
Phone +49 9161 788 861 | E-Mail: tama@meinldistribution.eu | tama.de
Roland Meinl Musikinstrumente GmbH & Co. KG | Budapest, Pf.:38 | 1507 Magyarország